



Three-Phase Solar Pump Controller 5.5 kW 380V - WIFI User Manual

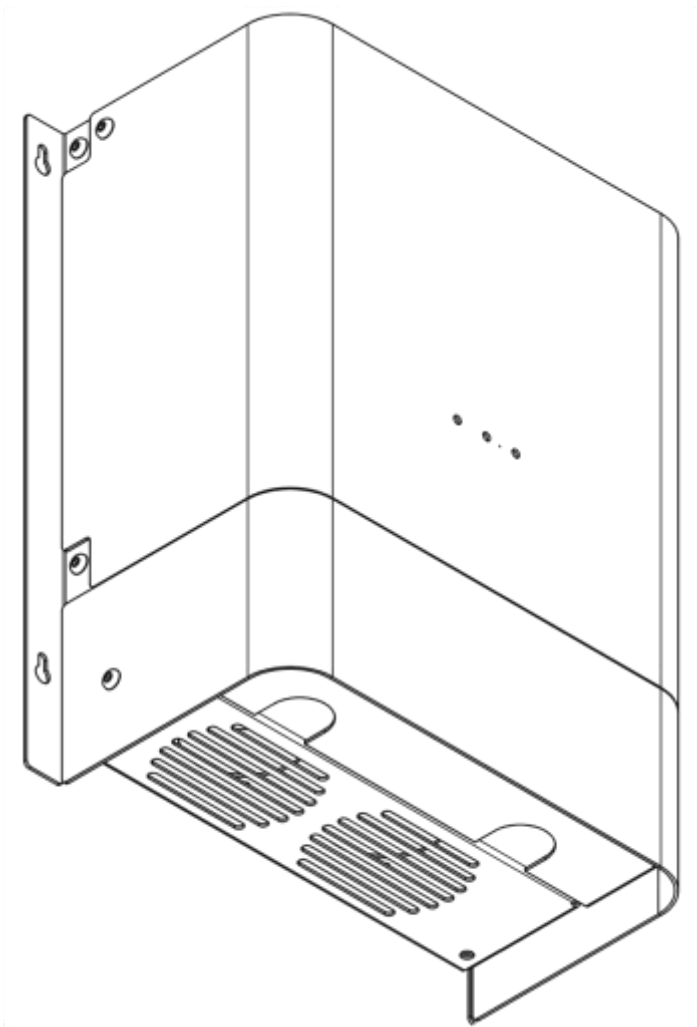

Table of Contents

1.	IMPORTANT INFORMATION AND SAFETY INSTRUCTIONS	1
2.	INTRODUCTION	2
2.1	General Description	2
2.2	Key Features.....	2
3.	OVERVIEW	3
3.1	Solar Pump Controller Front View.....	3
3.2	Solar Pump Controller Bottom View.....	4
4.	SOLAR PUMP CONTROLLER INSTALLATION	5
4.1	PV Array Size.....	5
4.2	Planning the Installation	6
5.	GENERAL WIRING INFORMATION	6
5.1	Removing the Wiring Access Panel	7
5.2	Wiring.....	7
5.3	Earthing.....	7
5.4	AC Wiring.....	8
5.5	DC Wiring.....	8
5.6	Control Circuit Wiring	9
5.6.1	Borehole Level Switch Operation	9
5.6.2	Tank Float Switch Operation	9
6.	SOLAR PUMP CONTROLLER OPERATION.....	10
6.1	Front Panel and Description.....	10
7.	PUMP CONTROLLER SETTINGS	12
7.1	Motor Voltage.....	12
7.2	Max Frequency	12
7.3	Minimum Frequency.....	12
7.4	Power Limit	12
7.5	Under Frequency	12
7.5.1	Under Frequency Trip Time.....	12
	(Default setting = 30 seconds, programmable from 3 sec to 3 hours or Disabled).....	12
7.5.2	Under Frequency Automatic Restart Time.....	12
7.6	Water Level Detection.....	13
7.6.1	Water level Low & Float Switch Low Trip Time.....	13
7.6.2	Water Level Low & Float Switch Auto Restart Time	13
7.7	Dry Run.....	13
7.7.1	Dry Run Power	13
7.7.2	Dry Run Trip Time	13

7.7.3	Dry Run Auto Restart Time.....	13
7.8	Phase Loss	13
7.8.1	Phase Loss Trip Time.....	13
7.8.2	Phase Loss Auto Restart Time	14
7.9	Short Circuit	14
7.9.1	Short Circuit Trip Time.....	14
7.9.2	Short Circuit Auto Restart Time	14
7.10	Over Temperature	14
7.10.1	Over Temperature Trip Time	14
7.10.2	Over Temperature Auto Restart Time	14
8.	CHECKS PRIOR TO START-UP.....	15
8.1	Start-Up Procedure	15
8.2	Maintenance and service	15
9.	PROGRAMMING VIA DIP SWITCHES	16
9.1	Programming Example:.....	16
9.2	Programming Chart.....	17
9.3	Programming Factory Reset	21
10.	PROGRAMMING VIA WI-FI	22
10.1	Connecting between your Android phone and the Controller Wi-Fi Module.....	22
10.1.1	Manually:	22
10.2	Device information page	23
10.3	Landing Page	24
10.4	GRAPHS.....	25
10.5	Device Settings	26
10.5.1	General Settings.....	26
10.5.2	Protection Settings	27
10.5.3	Regulations Settings.....	28
10.5.4	Hold-Off Settings	29
10.5.5	Restart Settings	30
11.	PUMP CONTROLLER SPECIFICATIONS	31
12.	DESTRIER ELECTRONICS LIMITED CARRY- IN WARRANTY	32
13.	REGISTRATION OF MY MICROCARE PRODUCT	33

1. IMPORTANT INFORMATION AND SAFETY INSTRUCTIONS

- Installers should be qualified electricians or technicians
- The installation information in the manual is for information purposes only.
- The monitoring and operation information in this manual is intended for anyone who needs to operate the controller.
- The pump controller output cannot be paralleled with another pump controller or AC source.
- Read the instructions carefully before installing and operating the pump controller.
- Connection and installation instructions must be followed.
- The unit should only be opened by skilled personal.
- To reduce risk of electric shock, disconnect all wiring before making any attempt to maintain or cleaning the unit. Turning off the PUMP CONTROLLER will not reduce this risk.
- Retain the load within in the rating to prevent faults.
- Mount the pump controller vertically.
- Do not install the pump controller on a rugged or inclined surface.
- Do not install the pump controller where it would be exposed to direct sunlight.
- Do not remove the top cover of the pump controller.
- Do not block or obstruct the heat sink fins.
- Sketches are intended for illustrative purposes only and are not intended to provide an electrical design.

This manual applies to all the 5,5kW 3PH Wi-Fi Pump Controllers with serial numbers ending with the suffix – “N”

Please ensure that the motor is suitable for use with a Variable Speed Drive



WARNING

Cover the entire PV array with an opaque material or thick black plastic before connecting or disconnecting the pump controller from the PV array.



WARNING

HIGH VOLTAGES PRESENT

Voltages capable of causing severe injury or death by electrical shock are present in this unit.

2. INTRODUCTION

2.1 General Description

The Microcare Three Phase Solar Pump Controller is designed to provide power to remote applications of motors and pumps. Driven by innovation the unit is a Maximum Power Point Tracker (MPPT) facilitating a maximum power generation for efficient usage. With its variable speed selectable control and flow switch input the unit is able to offer a true Solar Pump Controller capable of producing high efficiency and maximum power output. A unique overdrive feature which allows a lower PV voltage operation is built into the unit.

2.2 Key Features

- Surge Protection
- Compatible with any 3phase 380V motors
- LED status feedback
- High - Low water probes input
- Float switch input
- Trip and restart controls
- IP44 rated enclosure
- Built in Variable Speed Drive (VSD)
- Unique overdrive feature allows lower PV Voltage operation
- No external enclosure box required

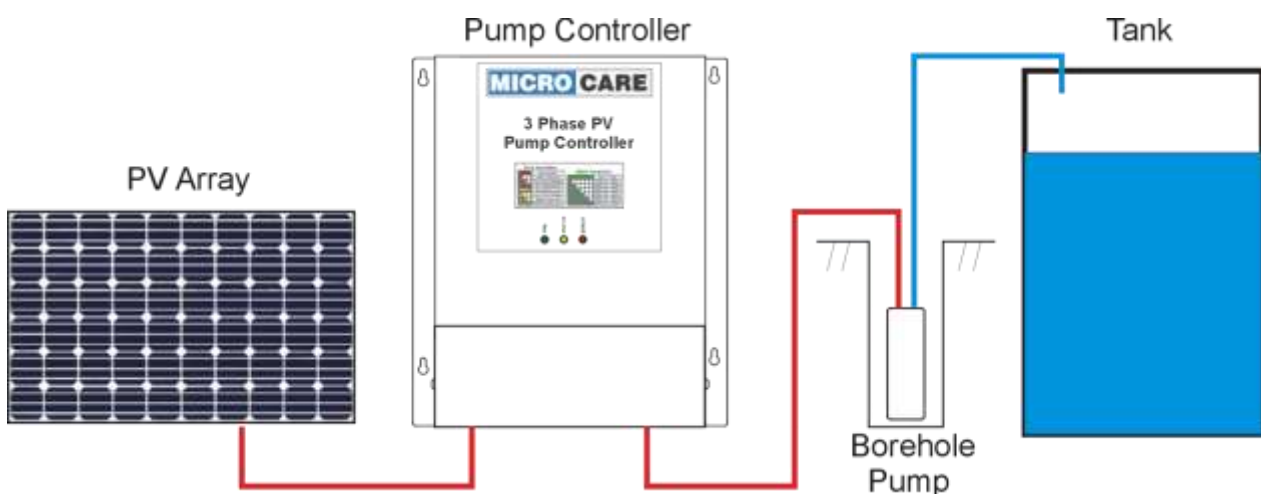
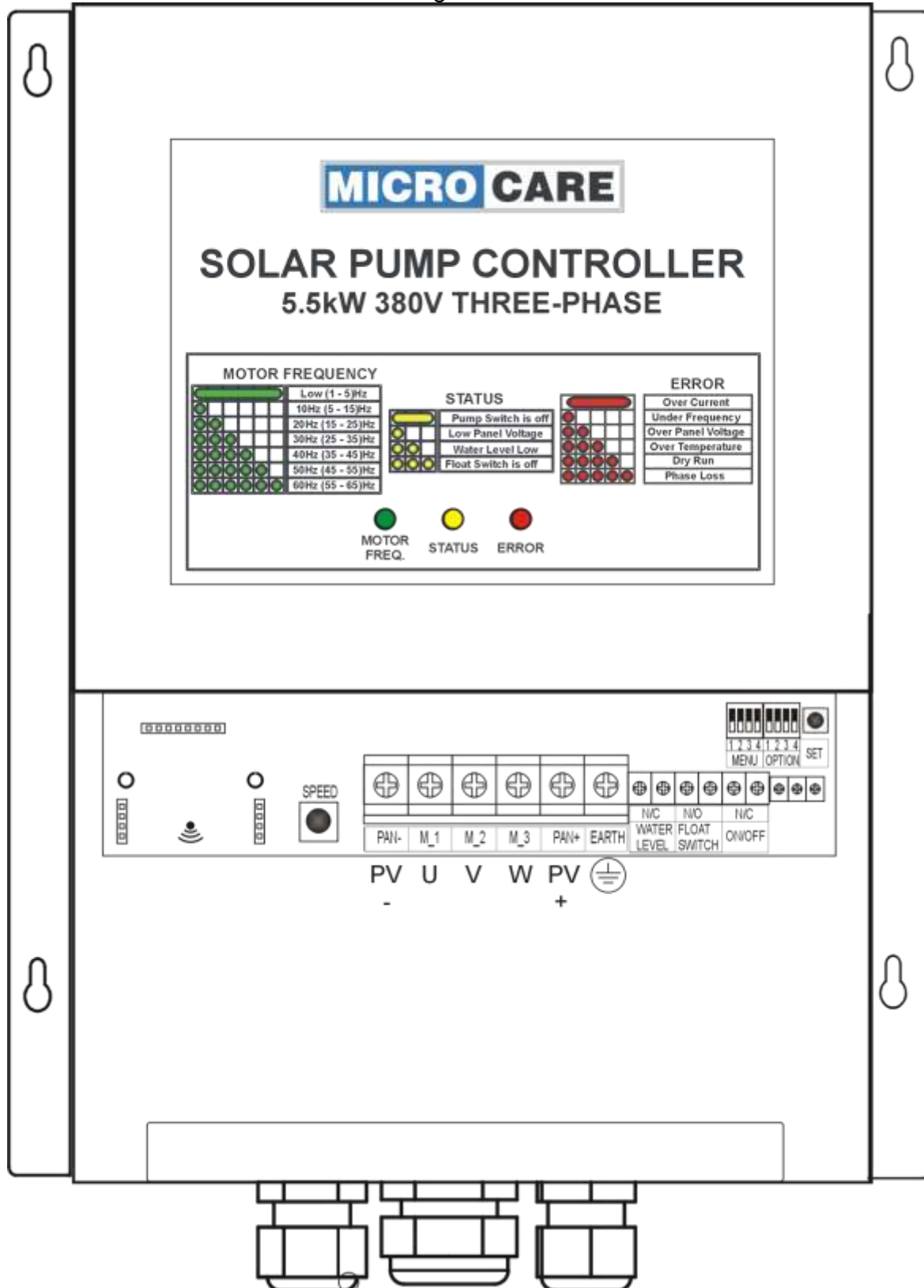

Fig 1: Basic solar pump system

3. OVERVIEW
 3.1 Solar Pump Controller Front View

Figure 3-1



3.2 Solar Pump Controller Bottom View

Figure 3-2

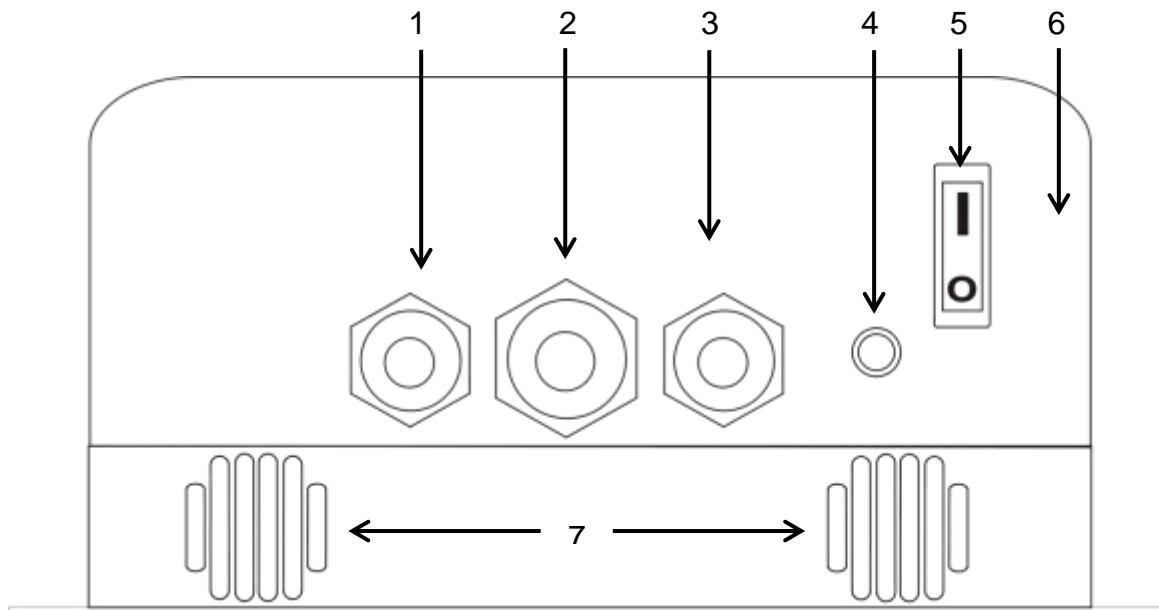

No	Description
1	Negative PV DC Wire “-“ Gland
2	Motor Wiring Gland
3	Positive PV DC Wiring “+“ Gland
4	Control Wiring Gland
5	Pump Off/On switch
6	Controller Bottom View
7	Ventilation Holes

4. SOLAR PUMP CONTROLLER INSTALLATION

Consider the following when installing the solar pump controller

4.1 PV Array Size

For optimal performance the PV array should be sized a least 1,7 times the size of the pump. This will ensure a longer period of water flow in daytime.

Pump Size	PV Array Wattage
1750W	2975W
2200W	3740W
3000W	5100W
4000W	6800W
5500W	9350W

Refer to the specification sheet on page 30, for the required minimum PV VOC and VMP voltage.

4.2 Planning the Installation

Location

- Install the solar pump controller underneath the solar panel array, away from sources of high temperature, direct sunlight, rainfall and away from any sources of moisture.
- The unit must be mounted in a vertical position.
- Find a suitable temperature resistant surface to mount the pump controller (If possible)
- Do not mount the pump controller in a closed container.
- Unrestricted airflow is required for the pump controller to operate at optimal efficiency.
- Ensure a 100cm unrestricted clearance at the bottom and 20cm above the pump controller.
- Keep the surrounding area clear of vegetation.

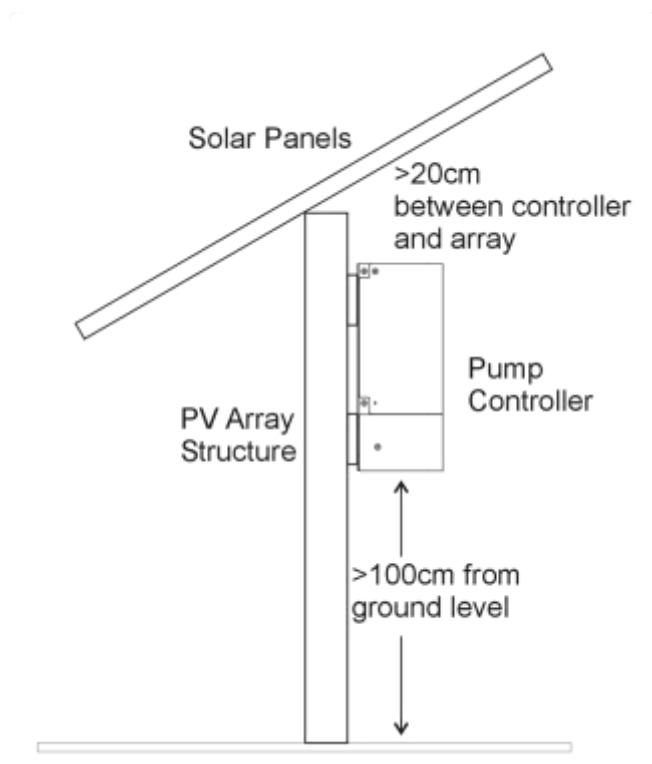

Fig 4-1: Required distances for ventilation and position for installation.

WARNING

Cover the entire PV array with an opaque material or thick black plastic before connecting or disconnecting the pump controller from the PV array.

5. GENERAL WIRING INFORMATION

WARNING

HIGH VOLTAGES PRESENT

Voltages capable of causing severe injury or death by electrical shock are present in this unit.

- Wiring must be performed by qualified personnel / certified electrician 
- Familiarize yourself with the content of the manual following before commencing with the wiring
- The DC array voltage applied must comply with the pump controller's specified input voltage.
- Do not connect the pump controller AC output directly to another AC source.
- The pump controller is not designed for parallel operation with another controller.

5.1 Removing the Wiring Access Panel

To access the wiring compartment, remove the 4 screws as indicated below.

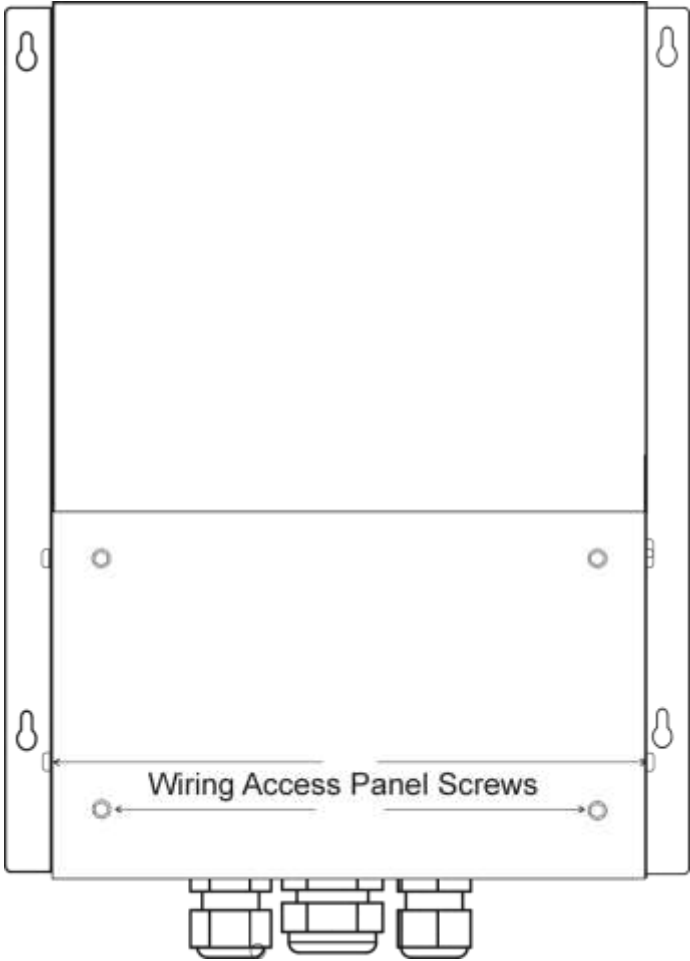

5.2 Wiring

- Switch the pump controller On/Off switch to the OFF position and cover the entire PV array with an opaque material or thick black plastic before connecting or disconnecting the pump controller from the PV array Remove the bottom wiring access panel by removing the 4 screws see 5.1.

5.3 Earthing

 The solar panel frames, PV array structure, solar pump controller and the pump must be earthed to an earth spike.

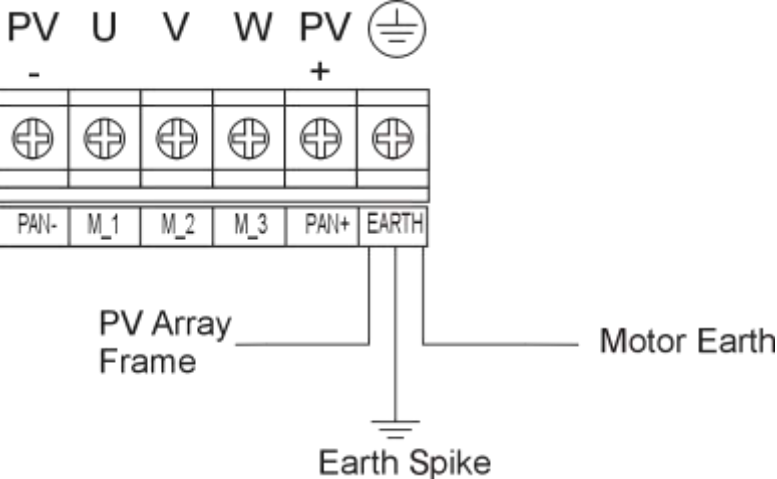

5.4 AC Wiring

- The pump/motor wiring must be sized correctly.
- Connect the four wires from the motor to the AC wiring connector block.
- Tighten the connector block terminals screws firmly.

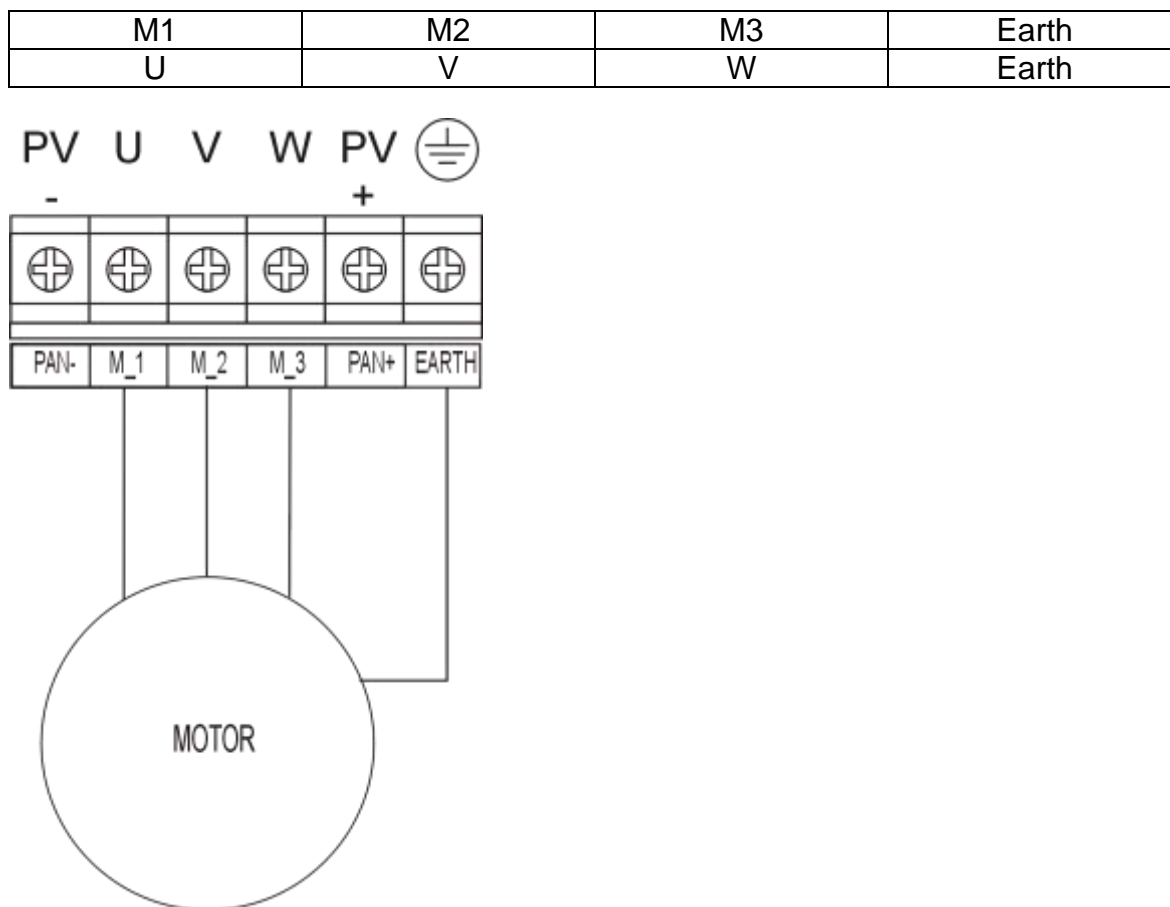

Figure 5-1: Motor wiring connection

5.5 DC Wiring



Warning! The pump controller input is not reverse polarity protected. Reverse polarity will damage the unit!!

- Ensure that the PV array wiring polarity is correct.
- Connect the Positive wire from the PV array to the + PV MC4 connector.
- Connect the Negative wire from the PV array to the – PV MC4 connector.

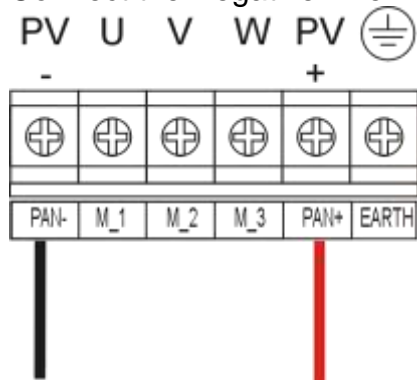

5.6 Control Circuit Wiring

When the water level connectors are closed and the tank float switch is open, the pump controller will start the pump.

5.6.1 Borehole Level Switch Operation

- Water level connects to the borehole pump water level switch.

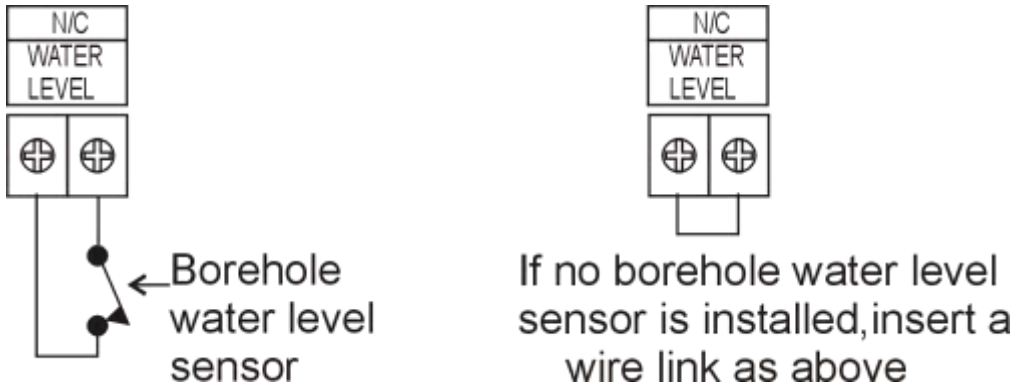

5.6.2 Tank Float Switch Operation

- High level tank float switch, when the water rises to the High Level threshold, the solar pump controller stops the pump. When the Float Switch is closed the controller stops the pump.

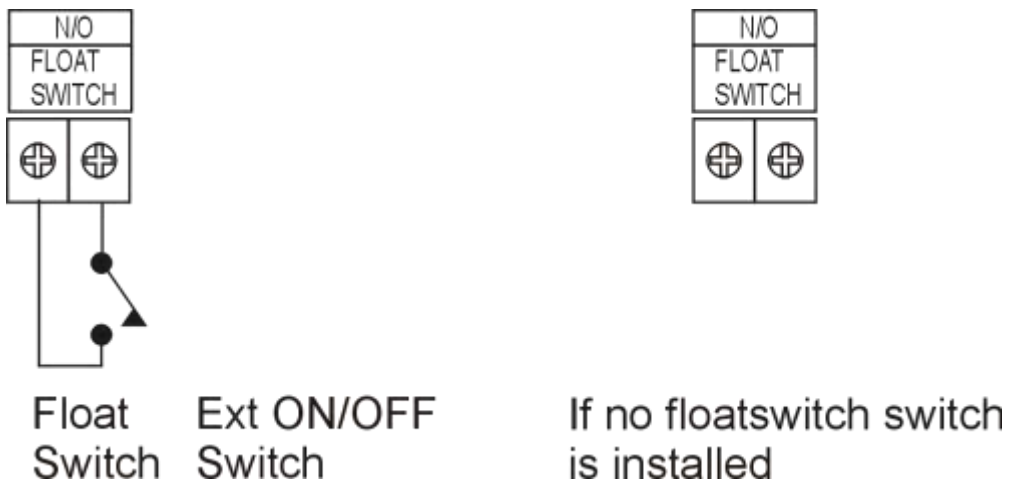

6. SOLAR PUMP CONTROLLER OPERATION

6.1 Front Panel and Description

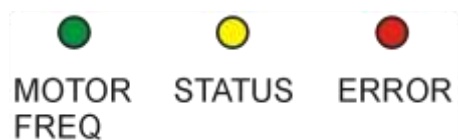

LED explanation:

- = LED is steady on
- = LED flashes once, pauses, flashes once etc.
- = LED flashes twice, pauses, flashes twice etc.

MOTOR FREQ

	Low (1 - 5)Hz
	10Hz (5 - 15)Hz
	20Hz (15 - 25)Hz
	30Hz (25 - 35)Hz
	40Hz (35 - 45)Hz
	50Hz (45 - 55)Hz
	60Hz (55 - 65)Hz

Indicates the motor frequency

STATUS

	Run Switch is off
	Low Panel Voltage
	Water Level Low
	Float Switch Closed

Run Switch is Off: The speed control on/off switch is off .

Low Panel Voltage: Panel voltage is below the minimum operating voltage.

Water Level Low: Borehole pump water level switch is not connected or the the water level in the borehole is low.

External Input is off: Tank is full or the pump is manually switched off.

ERROR

	Over Current
	Under Frequency
	Over Panel Voltage
	Over Temperature
	Dry Run
	Phase Loss

Over Current – The current limit of the controller is exceeded.

Under Frequency – Motor frequency is too low.

Over Panel Voltage – The PV DC input is above the specified voltage.

Over Temperature – The controller has exceeded its operating temperature.

Dry Run – The pump has run dry

Phase Loss – Loss of one or more phases

Power Limiting Warning

MOTOR FREQ

[Green bar]									
[Green]	[]	[]	[]	[]	[]	Low (1 - 5)Hz			
[Green]	[Green]	[]	[]	[]	[]	10Hz (5 - 15)Hz			
[Green]	[Green]	[Green]	[]	[]	[]	20Hz (15 - 25)Hz			
[Green]	[Green]	[Green]	[Green]	[]	[]	30Hz (25 - 35)Hz			
[Green]	[Green]	[Green]	[Green]	[Green]	[]	40Hz (35 - 45)Hz			
[Green]	[Green]	[Green]	[Green]	[Green]	[Green]	50Hz (45 - 55)Hz			
[Green]	[Green]	[Green]	[Green]	[Green]	[Green]	60Hz (55 - 65)Hz			

ERROR

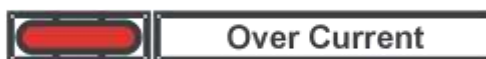

A power limit warning is the combination of the Motor Freq and Over Current LED's.

Eg: Green LED's flash 5 times and the Over Current LED is solid on.

This indicates that the Controller is limiting power to the motor.

Possible cause:

The power limit on the controller is set to low.

The motor exceeds the rated power of the controller.

Temperature Power Limiting Warning

MOTOR FREQ

[Green bar]									
[Green]	[]	[]	[]	[]	[]	Low (1 - 5)Hz			
[Green]	[Green]	[]	[]	[]	[]	10Hz (5 - 15)Hz			
[Green]	[Green]	[Green]	[]	[]	[]	20Hz (15 - 25)Hz			
[Green]	[Green]	[Green]	[Green]	[]	[]	30Hz (25 - 35)Hz			
[Green]	[Green]	[Green]	[Green]	[Green]	[]	40Hz (35 - 45)Hz			
[Green]	[Green]	[Green]	[Green]	[Green]	[Green]	50Hz (45 - 55)Hz			
[Green]	[Green]	[Green]	[Green]	[Green]	[Green]	60Hz (55 - 65)Hz			

ERROR

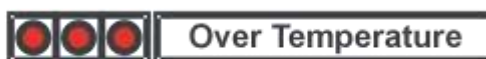

A power limit warning due to high temperature is the combination of the Motor Freq and Over Temperature LED's.

if the heatsink Temperature exceeds 70 degree Celsius the controller starts to Power Limit the motor due to temperature.

Eg: Green LED's flash 4 times and the RED LED flashes 3 times

This indicates that the Controller is limiting power to the motor.

The controller will continue to operate and will reduce the output power and operate until the temperature reaches 99 degrees Celsius, please note that controller will not operate at a frequency lower than the set Minimum Frequency.

At 100 degrees the controller will shut down, and wait for the temperature to cool down to 45 degrees before starting up again.

7. PUMP CONTROLLER SETTINGS

7.1 Motor Voltage

(Default setting = 380VAC, Programmable 380VAC, 400VAC, 410VAC, 200VAC, 220VAC, **219VAC, 230VAC, 240VAC, **379VAC.)

The voltages marked ****219VAC** and ****379VAC** can be used when the Motor will be run at a lower frequency due to an undersized PV Array. Please Contact out Technical Support for more information regarding these settings.

Please note:

For 200VAC, 219VAC, 220VAC, 230VAC, 240VAC operation the Max Controller Rated power is 3.0 kW (3000 Watt).

7.2 Max Frequency

(Default setting = 50Hz, programmable from 50 to 65Hz)

Sets the maximum frequency at which the motor can operate. Refer to the motor specifications.

7.3 Minimum Frequency

(Default setting = 5Hz, programmable from 5 to 45Hz)

Sets the minimum frequency at which the motor can operate. Refer to the motor specifications.

7.4 Power Limit

(Default setting = 7300W, programmable from 375 to 7300W)

Set the power equal to the running power (Wattage) of the pump motor.

Running Power = Motor Voltage x Max Running Current x $\sqrt{3}$ x Power Factor.

Get the above values from the motor specification sheet

7.5 Under Frequency

7.5.1 Under Frequency Trip Time

(Default setting = 30 seconds, programmable from 3 sec to 3 hours or Disabled)

- When the controller senses an under frequency condition for longer than the set Under Freq Trip Time, the controller stops the pump.
- If disabled is selected the controller will not stop the pump due to under frequency.

7.5.2 Under Frequency Automatic Restart Time

(Default setting = 5 seconds, programmable from 3 sec to 3 hours or No Auto Restart)

- As soon as the under frequency condition clears, the controller starts the pump after the restart timer, times out.
- If the under frequency is caused by low PV voltage, the Panel Low Voltage status will be displayed.
- As soon as the panel voltage reaches the required level, the controller starts the pump.
- If No Auto Restart is selected, the controller stops the pump during an under frequency condition.
- The controller will reset at the next daybreak or by manually switching the controller off and on again.

7.6 Water Level Detection

7.6.1 Water level Low & Float Switch Low Trip Time

(Default setting = 5 seconds, programmable from 3 sec to 3 hours or Disabled)

- If the controller senses a low water level condition for a set time “Trip Time”, it stops the pump.
- If disabled is selected the controller will not detect a Water Level Low or Float Switch condition and the pump continues to pump.

7.6.2 Water Level Low & Float Switch Auto Restart Time

(Default setting = 5 seconds, programmable from 3 sec to 3 hours or No Auto Restart)

- As soon as the water rises to the required level, the controller starts the pump after the set “Auto Restart Time” times out.
- If No Auto Restart is selected, the controller stops the pump during low water level condition.
- The controller will reset at the next daybreak or by manually switching the controller off and on again

7.7 Dry Run

7.7.1 Dry Run Power

(Default setting = 350W , programmable from 100W to 1500W)

When the water level in the borehole drops below the pump inlet the pump will run dry. During this condition the pump consumes less power than the minimum load power.

When the pump running power is less than the set Dry Run Power, the frequency is above 45Hz and the Dry Run Trip time is exceeded, the controller stops the pump.

The Dry Run Power is defined as below.

Dry Run Power = Motor Wattage x $\sqrt{3}$ x Power Factor of the motor X Dry Run Percentage

Example:

Dry Run Power = 1500 x $\sqrt{3}$ x 0,8 x 30% = 2287W

Set the dry run power according to the table on **page 19**. Use the highest value closest to the calculated value. In this case 2400W.

7.7.2 Dry Run Trip Time

(Default setting = 3 seconds, programmable from 3 sec to 3 hours or Dry Run Disabled)

- When the controller detects a dry run condition for more than the set Dry Run Trip Time the controller stops the pump.

7.7.3 Dry Run Auto Restart Time

(Default setting = 30 seconds, programmable from 3 sec to 3 hours or No Auto Restart)

- As soon as the water rises to the required level, the controller starts the pump after the set “Auto Dry Run Restart Time” times out.
- If No Auto Restart is selected, the controller stops the pump due to Dry Run Detection.
- The controller will reset at the next daybreak or by manually switching the controller off and on again.

7.8 Phase Loss

If the Phase Loss LED lights up, the system has shut down due to a Phase Loss.

7.8.1 Phase Loss Trip Time

(Default setting = 3 seconds, programmable from 3 sec to 3 hours or Phase Loss Trip Time Disabled)

- When the controller detects a Phase Loss for more than the set Phase Loss Trip Time the controller stops the pump.
- If disabled is selected the controller will not trip due to a Phase Loss.

7.8.2 Phase Loss Auto Restart Time

(Default setting = 30 seconds, programmable from 3 sec to 3 hours or No Auto Restart)

- As soon as a phase loss is not detected the controller starts the pump after the set “Phase Loss Restart Time” times out.
 - If No Auto Restart is selected, the controller stops the pump due to a Phase Loss.
 - The controller will reset at the next daybreak or by manually switching the controller off and on again.
-

7.9 Short Circuit

If the Over Current LED lights up and stays steady ON, the system has shut down due to a short circuit.

7.9.1 Short Circuit Trip Time

(Default setting = 3 seconds, programmable from 3 sec to 3 hours or Short Circuit Trip Time Disabled)

- When the controller detects a Short Circuit for more than the set Short Circuit Trip Time the controller stops the pump.
- If disabled is selected the controller will not trip due to a short circuit.

7.9.2 Short Circuit Auto Restart Time

(Default setting = 30 seconds, programmable from 3 sec to 3 hours or No Auto Restart)

- As soon as short circuit is cleared the controller starts the pump after the set “Auto Short Circuit Restart Time” times out.
 - If No Auto Restart is selected, the controller stops the pump due to a Short Circuit.
 - The controller will reset at the next daybreak or by manually switching the controller off and on again.
-

7.10 Over Temperature

If the Over Temperature LED lights up, the system has shut down due to over temperature.

7.10.1 Over Temperature Trip Time

(Default setting = 3 seconds, programmable from 3 sec to 3 hours or Short Circuit Trip Time Disabled)

- When the controller detects Over Temperature for more than the set Over Temperature Trip Time the controller stops the pump.
- If disabled is selected the controller will not trip due to over temperature.

7.10.2 Over Temperature Auto Restart Time

(Default setting = 30 seconds, programmable from 3 sec to 3 hours or No Auto Restart)

- As soon as the temperature is within the operating level of the controller the controller starts the pump after the set “Over Temperature Restart Time” times out.
- If No Auto Restart is selected, the controller stops the pump due to an over temperature condition.
- The controller will reset at the next daybreak or by manually switching the controller off and on again.

8. CHECKS PRIOR TO START-UP

Ensure that the pump controller is switched off.



Ensure that the pump controller is mounted vertically.
 Check that the Input and Output cables are secured.
 Check if the PV DC input voltage meets the pump controller rating.
 Ensure the correct polarity of the PV connections.
 Ensure that the
 Remove the opaque material or thick black plastic from the PV array.

8.1 Start-Up Procedure

- Switch the pump controller on.

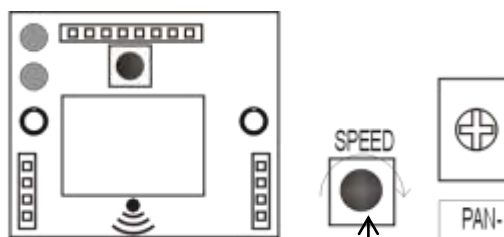

- The motor will start if sufficient power from the PV array is available.
- The speed can be adjusted by turning the speed control clockwise or anti-clockwise.
- The pump controller switches off after the first 30 minutes and restarts within 3 seconds, Thereafter it switches off every hour and restarts within 3 seconds

Re-fit the wiring cover and secure with the 2 screws if no further programming is necessary.

8.2 Maintenance and service

- The solar pump controller requires very little maintenance.
- Ensure that the vegetation below the pump controller is kept as short as possible.
- Ensure that the pump controller heat sink is free of dirt.

9. PROGRAMMING VIA DIP SWITCHES

Programming via DIP switches is performed by means of DIP switches located at the bottom of the controller. The controller must be connected to the PV array and the array must produce sufficient power in order to program the controller. Turn the Controller ON/OFF Switch to the off position. If the Yellow Status LED is steady “ON”, you can commence with programming. Refer to the programming chart for the Dip Switch Settings and section 9.1 Programming Example.

2 Banks of 4 way Dip Switches

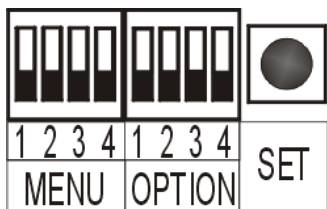

Menu

Selects the programming menu: Maximum Frequency, Power Limit, etc.

Option

Sets the parameter value eg: Hz, seconds etc.

Set

Saves the set Value.

9.1 Programming Example:

To program the Controller’s Maximum frequency to 53Hz.

Step 1: Switch the controller On/Off Switch to the “OFF” position.

From the programming chart Max Frequency set the DIP switches to the corresponding settings.

Step 2:

Set Dipswitch “MENU” according to the switch configuration on the programming chart 9:2

Step 3:

Set Dipswitch “OPTION” according to the switch configuration on the programming chart.

Step 4:

Push the “SET Button” for 2 seconds to save the selected setting.

The Green LED will flash once to indicate that the setting has been saved.

Max Frequency (Hz)													
Menu	Option												
<table border="1"> <tr><td>■</td><td></td><td></td><td></td></tr> <tr><td></td><td>■</td><td>■</td><td>■</td></tr> </table>	■					■	■	■	50				
■													
	■	■	■										
<table border="1"> <tr><td>■</td><td></td><td></td><td></td></tr> <tr><td></td><td></td><td>■</td><td>■</td></tr> <tr><td></td><td></td><td></td><td>■</td></tr> </table>	■						■	■				■	51
■													
		■	■										
			■										
<table border="1"> <tr><td></td><td></td><td>■</td><td></td></tr> <tr><td>■</td><td></td><td></td><td>■</td></tr> <tr><td></td><td></td><td></td><td>■</td></tr> </table>			■		■			■				■	52
		■											
■			■										
			■										
<table border="1"> <tr><td>■</td><td>■</td><td></td><td></td></tr> <tr><td></td><td></td><td></td><td>■</td></tr> <tr><td></td><td></td><td></td><td>■</td></tr> </table>	■	■						■				■	53
■	■												
			■										
			■										
<table border="1"> <tr><td>■</td><td>■</td><td></td><td></td></tr> <tr><td></td><td></td><td>■</td><td></td></tr> <tr><td>■</td><td>■</td><td></td><td>■</td></tr> </table>	■	■					■		■	■		■	54
■	■												
		■											
■	■		■										

To program another setting repeat steps 2, 3 and 4 or switch the ON/OFF switch to the ON position to resume operation.

9.2 Programming Chart

Motor Voltage (VAC)		Max Frequency (Hz)		Min Frequency (Hz)		Power Limit (W)	
Menu	Option	Menu	Option	Menu	Option	Menu	Option
	380		50		5		7300
	400		51		6		6750
	410		52		7		5500
	200		53		8		4750
	**219		54		9		4250
	220		55		10		4000
	230		56		15		3700
	240		57		20		3000
Reserved Do Not Use			58		25		2750
	**379		59		30		2200
			60		35		2000
			61		40		1500
			62		45		1100
			63		45		750
			64		45		550
			65		45		375
Default Setting		Default Setting		Default Setting		Default Setting	
380V		50Hz		5Hz		7300W	

More programming charts on the next page

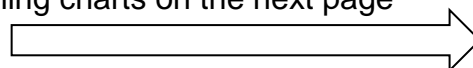

Under Frequency TripTime (sec/min/hrs)		Under Frequency Auto Restart Time (sec/min/hrs)		High_Low + Float Trip Time (sec/min/hrs)		High_Low + Float Auto Restart Time (sec/min/hrs)	
Menu	Option	Menu	Option	Menu	Option	Menu	Option
	3s		3s		3s		3s
	5s		5s		5s		5s
	15s		15s		15s		15s
	30s		30s		30s		30s
	1min		1min		1min		1min
	2min		2min		2min		2min
	5min		5min		5min		5min
	10min		10min		10min		10min
	15min		15min		15min		15min
	30min		30min		30min		30min
	45min		45min		45min		45min
	1hr		1hr		1hr		1hr
	1h30m		1h30m		1h30m		1h30m
	2h		2h		2h		2h
	3h		3h		3h		3h
Disabled		No Restart		Disabled		No Restart	

Default Setting	Default Setting	Default Setting	Default Setting
30 Seconds	5 Seconds	5 Seconds	5 Seconds

More programming charts on the next page

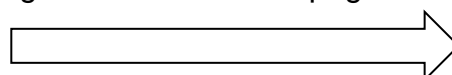

Dry Run Trip Time (sec/min/hrs)		Dry Run Reset Time (sec/min/hrs)		Dry Run Power W		Regulation	
Menu	Option	Menu	Option	Menu	Option	Menu	Option
	3s		3s		335W		
	5s		5s		690W	Normal	
	15s		15s		1030W	Slow	
	30s		30s		1375W	Slower	
	1min		1min		1720W	Simple Mode	
	2min		2min		2060W	Fuzzy Logic	
	5min		5min		2400W	Contact our tech support before changing any regulation settings.	
	10min		10min		2750W		
	15min		15min		3100W		
	30min		30min		3440W		
	45min		45min		3780W		
	1hr		1hr		4125W		
	1h30m		1h30m		4470W		
	2h		2h		4810W		
	3h		3h		5150W		
Disabled		No Restart			5500W		

Default Setting	Default Setting	Default Setting	Default Setting
3 Seconds	30 Seconds	335W	Normal

Phase Loss Trip Time (sec/min/hrs)		Phase Loss Reset Time (sec/min/hrs)		More programming charts on the next page			
Menu	Option	Menu	Option	Menu	Option	Menu	Option
	3s		3s		3s		3s
	5s		5s		5s		5s
	15s		15s		15s		15s
	30s		30s		30s		30s
	1min		1min		1min		1min
	2min		2min		2min		2min
	5min		5min		5min		5min
	10min		10min		10min		10min
	15min		15min		15min		15min
	30min		30min		30min		30min
	45min		45min		45min		45min
	1hr		1hr		1hr		1hr
	1h30m		1h30m		1h30m		1h30m
	2h		2h		2h		2h
	3h		3h		3h		3h
Disabled		No Restart		Disabled		No Restart	

Default Setting	Default Setting	Default Setting	Default Setting
3 Seconds	30 Seconds	3 Seconds	30 Seconds

9.3 Programming Factory Reset

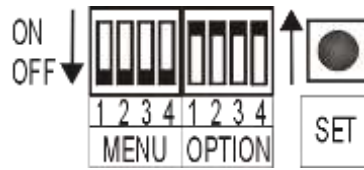

- Switch the controller On/Off Switch to the “**OFF**” position
- Set the **MENU** and **OPTION** DIP switches as per the above figure.
- “MENU” DIP Switches in the OFF position “down”
- “OPTION” DIP Switches in the On position “up”.
- Push and Hold the **SET** Button for 2 seconds.
- All the LED’s will flash once to indicate that the factory reset was successful.

10. PROGRAMMING VIA WI-FI

10.1 Connecting between your Android phone and the Controller Wi-Fi Module

10.1.1 Manually:

Ensure that the pump controller is switched on or power is connected to the controller and the Yellow Status LED is steady on.

To connect to the WIFI network click on the WIFI icon of your Laptop, Cellphone, Tablet, etc

Scan the list of available Wi-Fi Networks from your “device” (Laptop, Cellphone, Tablet etc)

You should now see a list of available networks.

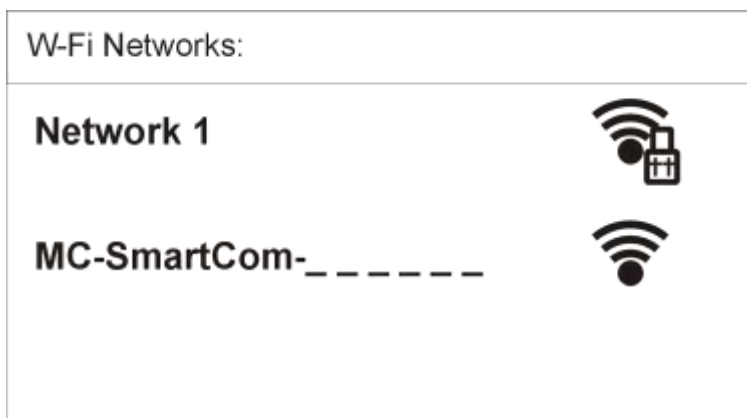

Select MC-Smartcom - SSID: MC-SmartCom-xxxxx – unique ID for each Wi-Fi module.

You will be prompted for a password

Default password is “Microcare” (without the quotes).

Select connect. Once connected open your Internet Browser on your device and click your mouse in the **address** bar at the top of the window.

In the address bar type: 192.168.123.1

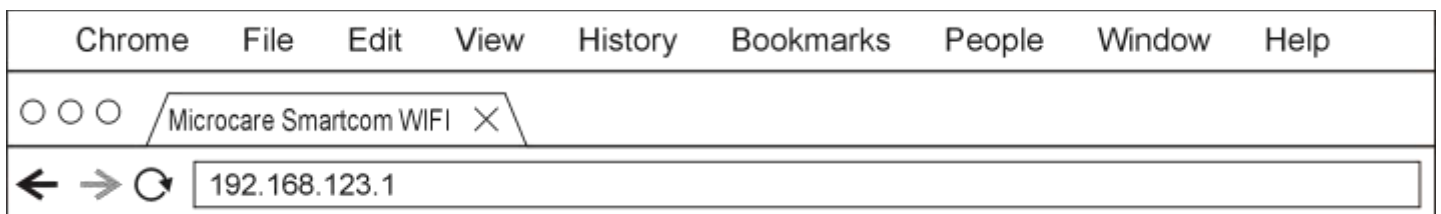

10.2 Device information page

The appropriate landing page will be displayed automatically

← → ↻ 192.168.123.1-/wi-fi/pump.html

Microcare Pump Controller
 Information from your Microcare Pump Controller is displayed below (last update 11:32)

[Index](#)

Output Power



0 Watts

Motor Frequency



0 Hz

Show
Real - Time ▼
Output Power (W) ▼

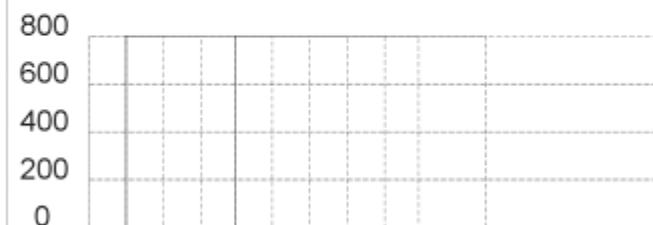

Output History

Device Information

Description	Value
Device Type	1,5 kW
Panel Voltage	580 V
Panel Current	0 A
Motor Voltage	0 V
Motor Frequency	0 Hz
Output Power	0 W
Temperature	48c
Device Status	Switched Off at Pump

Device Settings

General
Protection
Regulation
Hold Off
Restart
Reset To Default

Start

Summary

The following historical data can be displayed. Panel Voltage, Panel Current, Battery Voltage, Battery Current or Output Power.

The device information page shows the real-time information gather from your Microcare device. Below is an example

- Last page update , Output Power, Battery Voltage
- Performance graph shows the device performance over a period of time:
- Real-time Information is displayed by default and shows the data for the last 3 minutes.
- Historical information can be selected from the “Show” dropdown. The historical data shows the device performance over the last 24hours, averaged in 15 minute intervals.
The historical data will be lost in the event of Wi-Fi connections loss or by switching off the MPPT.

Various metrics can be selected from the “Show” dropdown such as:

- Output Power, Battery Voltage, Panel Voltage

Device information shows information about the connected device

10.3 Landing Page

← → ↻ 192.168.123.1-/wi-fi/pump.html

Microcare Pump Controller

Information from your Microcare Pump Controller is displayed below (last update 11:32)

[Index](#)

Output Power



0 Watts

Motor Frequency



0 Hz

Show
Real - Time ▼
Output Power (W) ▼

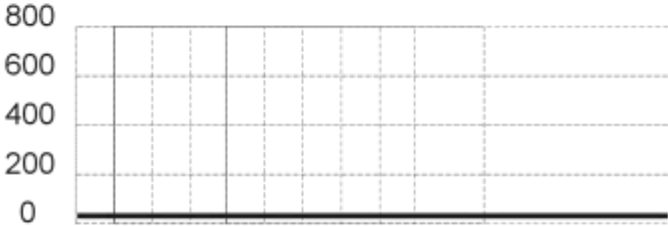

Output History

Device Information

Description	Value
Device Type	1,5 kW
Panel Voltage	580 V
Panel Current	0 A
Motor Voltage	0 V
Motor Frequency	0 Hz Start
Output Power	0 W Summary
Temperature	48c
Device Status	Switched Off at Pump

Device Settings

General
Protection
Regulation
Hold Off
Restart
Reset To Default

Motor Voltage	380 Volt	▼
Max Frequency	50	Hz
Min Frequency	30	Hz
VMP (0 = auto)	0	V
Power Point	75	%

Please stop the pump before saving

10.4 GRAPHS

Performance Show Real - Time ▼ Output Power (W) ▼

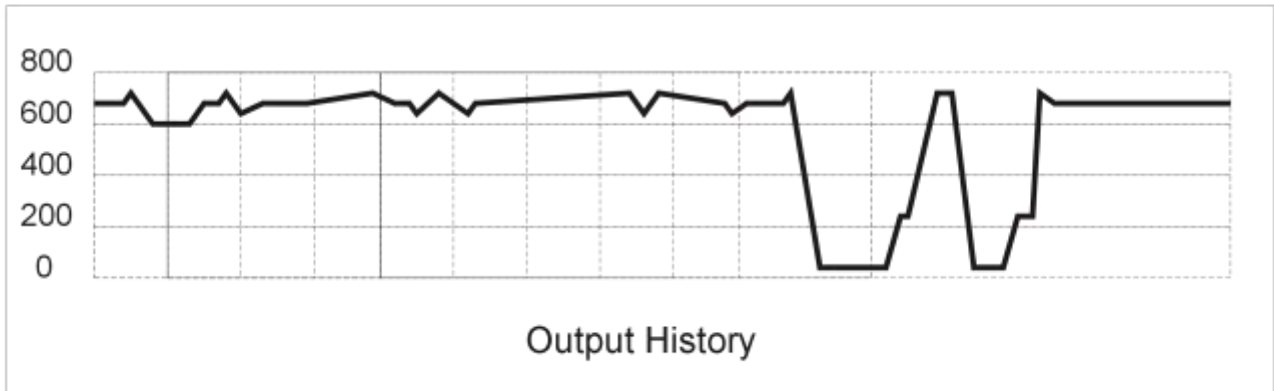

10.5 Device Settings

10.5.1 General Settings

Select the General Settings Tab and the following will be displayed.

Stop the pump before saving any setting changes.

Device Settings

General	Protection	Regulation	Hold Off	Restart	Reset To Default
Motor Voltage	380 Volt				
Max Frequency	50				Hz
Min Frequency	30				Hz
VMP (0 = auto)	0				V
Power Point	75				%

Please stop the pump before saving

General Settings	
Motor Voltage [V _{AC}] Sets the motor voltage: Default setting = 380VAC	200/219/220/230/240/379/380/400/410
Max Frequency [Hz] Sets the max running frequency Default =50Hz	30-50
Min Frequency [Hz] Sets the minimum running frequency Default= 5Hz	5-45
Vmp (0=Auto calculates VMP) Sets the Max Power Point Voltage Default= 0	Greater or equal to the recommended VMP
Power Point Calculates the VMP as a % of VOC Default=77%	Baseline Percentage of V _{OC} where MPPT tracks the Max Power Point Voltage

10.5.2 Protection Settings

Stop the pump before saving any setting changes.

Device Settings

General	Protection	Regulation	Hold Off	Restart	Reset To Default
Power Limit	2000				W
Motor Amps	10				A
Motor Power Factor	0,75				T
Dry Run Percent	90				%
Dry Run Power	100				W
Dry Run Frequency	45				Hz
Phase Loss Threshold	0,25				A
SS Parameter 1 Max	5				
SS Parameter 2 Avg Time	100				
SS Parameter 3 Avg	2				

Please stop the pump before saving

Protection Settings	
Power Limit (limits output if power exceeds set)	From 100-2000W → 1.5kW Controller From 100-7500W → 5.5kW Controller
Motor Amps [A]	Maximum input amps
Motor Power Factor	0.0-1.0
Dry Run Percentage	Percentage of Running Power during dry run
Dry Run Power	Pump power consumed during dry run
Dry Run Frequency	Min frequency for a dry run condition
Phase Loss Threshold	Do Not Change this setting
SS Parameter 1 Max	Do Not Change this setting
SS Parameter 2 Avg Time	Do Not Change this setting
SS Parameter 3 Avg	Do Not Change this setting

Required Values:

Motor Voltage: 380[V], Motor Amps: 2.3[A], Motor Power Factor: 0.8 , Dry Run Percentage: 20% = 0.2

Calculation: Suggested Dry Run Power = Motor Voltage × Motor Amps × Motor Power Factor × Dry Run Percentage × $\sqrt{3}$

$$\text{Suggested Dry Run Power} = 380 \times 2.3 \times 0.8 \times 0.2 \times \sqrt{3}$$

$$= 242 \text{ [W]}$$

10.5.3 Regulations Settings

Do not change these settings. Contact our Tech Support.

Stop the pump before saving any setting changes.

Device Settings

General Protection Regulation Hold Off Restart Reset To Default

Regulation Mode	Super fast PD
Rate Type	Low
Ramp Stage 1	Regulate at 2Hz/sec
Ramp Stage 2	Regulate at 5Hz/sec
PV Low Rate 1	Regulate at 1Hz/sec
PV Low Rate 2	Regulate at 1Hz/sec
PV Low Rate 3	Regulate at 1Hz/sec
PV Low Rate 4	Regulate at 25Hz/sec
PV Low Rate 5	Regulate at 200Hz/sec
PV High Rate 1	Regulate at 0,1Hz/sec
PV High Rate 2	Regulate at 0,5Hz/sec
PV High Rate 3	Regulate at 15Hz/sec

Please stop the pump before saving

Regulation Settings	
Regulation Mode	Simple Mode/Fuzzy Logic/Super PID/Super Fast PID*
Rate Type	
Ramp Stage 1	Start-up Slower Ramp Rate
Ramp Stage 2	Start-up Faster Ramp Rate
PV Low Rate 1	Slowest Ramp Down Rate
PV Low Rate 2	
PV Low Rate 3	
PV Low Rate 4	
PV Low Rate 5	Fastest Ramp Down Rate
PV High Rate 1	Slowest Ramp Up Rate
PV High Rate 2	
PV High Rate 3	Fastest Ramp Up Rate

10.5.4 Hold-Off Settings

When the controller senses a condition for longer than the set Time, the controller stops the pump.

Stop the pump before saving any setting changes.

Device Settings

General Protection Regulation **Hold Off** Restart Reset To Default

Freq Low Hold-Off	1	seconds(s)
High/Low Water Hold-Off	5	seconds(s)
On/Off Switch Hold-Off	1	seconds(s)
PV Amps High Hold-Off	1	seconds(s)
PV Voltage Low Hold-Off	30	seconds(s)
PV Volts High Hold-Off	5	seconds(s)
Temperature High Hold-Off	3	seconds(s)
Float Switch Hold-Off	5	seconds(s)
Dry Run Hold-Off	3	seconds(s)
Short Circuit Hold-Off	3	seconds(s)
Phase Loss Hold-Off	3	seconds(s)

Please stop the pump before saving

0 = Disables the error, e.g. if Dry Run Hold-Off is set to zero, the pump will never shut down when dry run occurs.

10.5.5 Restart Settings

As soon as condition is cleared the controller starts the pump after the set “Restart Time”

Stop the pump before saving any setting changes.

Device Settings

General Protection Regulation Hold Off Restart Reset To Default

Freq Low Restart	1	seconds(s)
High/Low Water Restart	5	seconds(s)
On/Off Switch Restart	1	seconds(s)
PV Amps High Restart	1	seconds(s)
PV Voltage Low Restart	30	seconds(s)
PV Volts High Restart	5	seconds(s)
Temperature High Restart	3	seconds(s)
Float Switch Restart	5	seconds(s)
Dry Run Restart	3	seconds(s)
Short Circuit Restart	3	seconds(s)
Phase Loss Restart	3	seconds(s)

Please stop the pump before saving

If any of the above settings are set to “0”, the controller will not restart and stays off until the error is cleared via the ON/OFF(toggle), Wi-Fi(start/stop) or a complete power reset(new day).

11. PUMP CONTROLLER SPECIFICATIONS

Model	5.5kW			
Output Voltage		380VAC	400VAC	410VAC
Rated Output Power		5.5kW		
Max PV VOC Input		850VDC		
Min PV Start Up VOC		>537VDC	>565VDC	>580VDC
Recommended PV VMP		530VDC	565VDC	580VDC
Output Voltage	200VAC	220VAC	230VAC	240VAC
Rated Output Power	3kW			
Max PV VOC Input	650VDC			
Min PV Start Up VOC	>285VDC	>310VDC	>325VDC	>339VDC
Recommended PV VMP	280VDC	310VDC	325VDC	340VDC
Output Voltage	Refer to section 7.1		**219VAC	**379VAC
Rated Output Power			3kW	5.5kW
Max PV VOC Input			650VDC	
Min PV Start Up VOC			>180VDC	>300VDC
Recommended PV VMP			310VDC	530VDC
Frequency Range	5 – 65Hz (Programmable)			
Ambient Temp Range	0°C to 40°C			
Protection	Overload, Short Circuit, Over Temperature, Under Voltage, Over Voltage, Surge Protection, Phase Loss			
Dimensions (H x W x D)	285 x 240 x 120mm			
Warranty	1 year			

12. DESTRIER ELECTRONICS LIMITED CARRY- IN WARRANTY

Destrier Electronics warrants the Three-Phase Solar Pump Controller against defects in workmanship and materials, fair wear and tear accepted, for a period of 1 (one) year from the date of delivery/collection for all equipment and is based on a carry-in basis. Where the installation of the product makes it impractical to carry-in to our workshops, Destrier Electronics reserves the right to charge for travel time and kilometres travelled to and from the site where the product is installed.

During this warranty period, Destrier Electronics will, at its own discretion, repair or replace the defective product free of charge. This warranty will be considered void if the unit has suffered any physical damage or alteration, either internally or externally, and does not cover damages arising from improper use such as, but not exclusive to:

- Reverse of battery polarity.
- Inadequate or incorrect connection of the product and/or of its accessories.
- Mechanical shock or deformation.
- Contact with liquid or oxidation by condensation.
- Use in an inappropriate environment (dust, corrosive vapour, humidity, high temperature, biological infestation.)
- Breakage or damage due to lightning, surges, spikes or other electrical events.
- Connection terminals and screws destroyed or other damage such as overheating due to insufficient tightening of terminals.
- When considering any electronic breakage except due to lightning, reverse polarity, over-voltage, etc. the state of the internal control circuitry determines the warranty.

This warranty will not apply where the product has been misused, neglected, improperly installed, or repaired by anyone else than Destrier Electronics or one of its authorised Qualified Service Partners. In order to qualify for the warranty, the product must not be disassembled or modified. Repair or replacements are our sole remedies. Destrier Electronics shall not be liable for damages, whether direct, incidental, special, or consequential, even caused by negligence or fault. Destrier Electronics owns all parts removed from repaired products. Destrier Electronics uses new or re-conditioned parts made by various manufacturers in performing warranty repairs and building replacement products. If Destrier Electronics repairs or replaces a part of a product, its warranty term is not extended. Removal of serial nos. may void the warranty.

All remedies and the measure for damages are limited to the above. Destrier Electronics shall in no event be liable for consequential, incidental, contingent or special damages, even if having been advised of the probability of such damages. Any and all other warranties expressed or implied arising by law, course of dealing, course of performance, usage of trade or otherwise, including but not limited to implied warranties of merchantability and fitness for a particular purpose, are limited in duration to a period of 1 (one) year from the date of purchase.

Life Support Policy:

As a general policy, Destrier Electronics does not recommend the use of any of its products in life support applications where failure or malfunction of the Destrier Electronics product can be reasonably expected to cause failure of the life support device or to significantly affect its safety or effectiveness.

Destrier Electronics does not recommend the use of any of its products in direct patient care. Destrier Electronics will not knowingly sell its products for use in such applications unless it receives in writing assurances satisfactory to Destrier Electronics that the risks of injury or damage have been minimised, the customer assumes all such risks, and the Liability of Destrier Electronics is adequately protected under the circumstances.

Caution:

Our products are sensitive. While all care is taken by us to dispatch goods with adequate packaging, Destrier Electronics is not responsible for any damages caused to products after they have left our premises.

13. REGISTRATION OF MY MICROCARE PRODUCT

Product Serial Number:

Product Description:

Date Purchased

Where was the Product Purchased?

Company Name

Contact Person

Contact Number

E-mail Address

Installation Company Information:

Company Name

Contact Person

Contact Number

E-mail Address

Details of Product Owner

Name & Surname

Address

City & Province

Contact Number

E-mail Address

Date Installed

Microcare: 1st Floor, Neave Industrial Park, Korsten, Port Elizabeth
P.O.Box 7227, Newton Park, 6055
Tel: 041 453 5761, Fax: 041 – 453 5763
Technical Support e-mail: support@microcare.co.za
Website: www.microcare.co.za

Registration by fax:

041 – 453 5763

Registration by e-mail:

support@microcare.co.za

Online Registration:

www.microcare.co.za/register-my-product