

**MICRO CARE**®

**SOLAR COMPONENTS**



1Kw / 2Kw / 3Kw / 5Kw

**PURE SINE WAVE**  
**BI-DIRECTIONAL**  
**INVERTER MANUAL**

**MICRO CARE**®

**SOLAR COMPONENTS**



# Contents

1. INTRODUCTION.....	2
2. SAFETY INSTRUCTION.....	3
3. SYSTEM DESCRIPTION.....	6
4. INVERTER OPERATION.....	8
5. INVERTER PROGRAMMING.....	13
6. SPECIFICATIONS OF INVERTERS.....	23

# **1. INTRODUCTION**

## **1.1 GENERAL DESCRIPTION**

The Microcare Pure Sine Wave Inverters deliver true clean sine wave output power. The Power is applicable for any kind of load, such as air-conditioners, home appliances, consumer electronics and office equipment. This series features a durable and continuous 24 hour operation. The compact and modular design makes utility interactive installations easier and more cost effective. It is a high quality product that offers the best price/performance ratio in the industry.

## **1.2 KEY FEATURES**

- 1.2.1 Multiple microprocessor design base.
- 1.2.2 Compatible with both linear and non-linear loads.
- 1.2.3 24 hour operation of the inverter.
- 1.2.4 DC start and automatic self-diagnostic function.
- 1.2.5 THD less than 3%.
- 1.2.6 Internal high power 3 stage charger.
- 1.2.7 High efficiency design to save electricity.
- 1.2.8 Low heat dissipation for long time operation.
- 1.2.9 Designed to operate in a harsh environment.
- 1.2.10 Wall Mounted.

## **1.3 IMPORTANT NOTICES**

- Read instructions carefully before operating Inverter.
- Inverter connection instructions must be followed.
- The unit should only be opened by skilled personal.
- Retain the load within in the rating of Inverter to prevent faults.
- Keep the Inverter clean and dry.
- If a 220vac supply is connected to the inverter and it is to be used as a UPS, then the inverter can only supply its rated power.

## **2. SAFETY INSTRUCTION**

### **2.1 POSITIONING**

- 2.1.1 Do not put the Inverter on a rugged or inclined surface.
- 2.1.2 Do not install the Inverter near water or in damp environments.
- 2.1.3 Do not install the Inverter where it would be exposed to direct sunlight.
- 2.1.4 Keep the Inverter far away from heat emitting sources.
- 2.1.5 Do not block ventilation openings in the inverter housing.
- 2.1.6 Do not leave objects on top of the Inverter.
- 2.1.7 Do not expose the Inverter to corrosive gasses.
- 2.1.8 Ambient temperature: 0°C – 40°C.

### **2.2 INSTALLATION**

**MOUNT THE SINGLE HANGING BRACKET ONTO THE WALL.**

**SLIDE THE INVERTER OVER THE BRACKET SO THE INVERTER HANGS FROM THE BRACKET.**

- 2.2.1 Connect the Inverter AC OUTPUT only to an earthed DB Panel.
- 2.2.2 The AC connections are located at the top of the inverter under the top side cover. (Where the Live and Neutral IN, Live and Neutral OUT and Earth Connections are.)
- 2.2.3 If a 220vAC supply or a generator is available, connect into the Live and Neutral IN Connection.
- 2.2.4 Make sure the BATTERY INPUT CIRCUIT BREAKER is OFF.
- 2.2.5 Place cables in such a way that no one can step on or trip over them.
- 2.2.6 Battery cables must be a minimum of 35mm<sup>2</sup> and as short as possible.
- 2.2.7 The battery cables come out at the bottom of the inverter, next to the BATTERY INPUT CIRCUIT BREAKER.
- 2.2.8 The unit must be mounted in a vertical position against the wall.
- 2.2.9 Minimum battery bank of 300A/Hours is suggested.

### **2.3 EARTHING OF EQUIPMENT**

Equipment surge protection products are an effective way of controlling dangerous surges that can enter a facility. When strategically placed and correctly installed, the Surge Protectors will effectively reduce harmful over voltage conditions that can damage electrical and electronic equipment.

It is important that the protection system includes both structural and surge protection equipment.

When lightning current passes into the ground through any conductor (Example: Tree Trunk) a powerful electromagnetic force is set up due to the fast rise times of the strike. This electromagnetic force then couples into any inductive loops that may be available in nearby buildings. When these currents equalize, damage usually occurs to the equipment.

## Lightning Protection Zones

LPZ0A:	This zone is an area where a direct hit to the structure is possible. The current may rise to a value of 200,000A (10/350 $\mu$ s) producing extremely high electromagnetic fields. Any conductor system must be capable of carrying the full lightning current.
LPZ0B:	This zone is an area where a direct hit is not possible, but high electromagnetic fields will be present. This zone is determined by the effectiveness of the structural protection system.
LPZ1:	Again, a direct hit in this area is not possible due to the screening measures applied. The electromagnetic field is much lower than LPZ0A and LPZ0B. It is in this zone where appropriate surge arresters may be fitted that will limit the value of surge current entering a facility.
LPZ2:	The value of surge current and electromagnetic field will be lower than that of LPZ1 when correct protection principles have been applied. It is in this area where sensitive electronic equipment may be safely installed.



- |       |                    |   |                           |
|-------|--------------------|---|---------------------------|
| 2.3.1 | LIVE IN and N IN   | — | Connect to Grid           |
| 2.3.2 | LIVE OUT and N OUT | — | Connect to AC Load.       |
| 2.3.3 | EARTH 1            | — | Connect to Earth Bar.     |
| 2.3.4 | EARTH 2            | — | Connect to Chassis Earth. |

The Microcare inverter is designed primarily for Grid / Mains connection to include charging. When Mains is connected to the inverter the Neutral connection is Earthed via the Mains.

If the Inverter is connected as a stand-alone inverter with no Mains Connection, The Neutral is required to be earthed using an earth spike.

**If the Inverter is not earthed; warranty will be null and void.**

### 2.3.5 Inverter Neutral Connection

The inverter has a floating neutral so the neutral voltage will be close to 110v. In this case the live voltage with respect to the earth will also be around 110v.

If you use your inverter for a standalone application you need to bridge the neutral input with the earth terminal on the inverter (these two are next to each other for this purpose). You can now fit an earth leakage after the inverter.

But if you are going to supply your inverter with AC from the grid then you need to put the inverter before the earth leakage and you need to keep the inverter neutral input connected to the GRID neutral at all times.

So if you want to switch the GRID input to the inverter off then one must only switch live. You can then put the earth leakage directly after the inverter. The grid will pull the inverter neutral to 0v.

#### 2.3.5 Inverter Earth Connection to Grid.

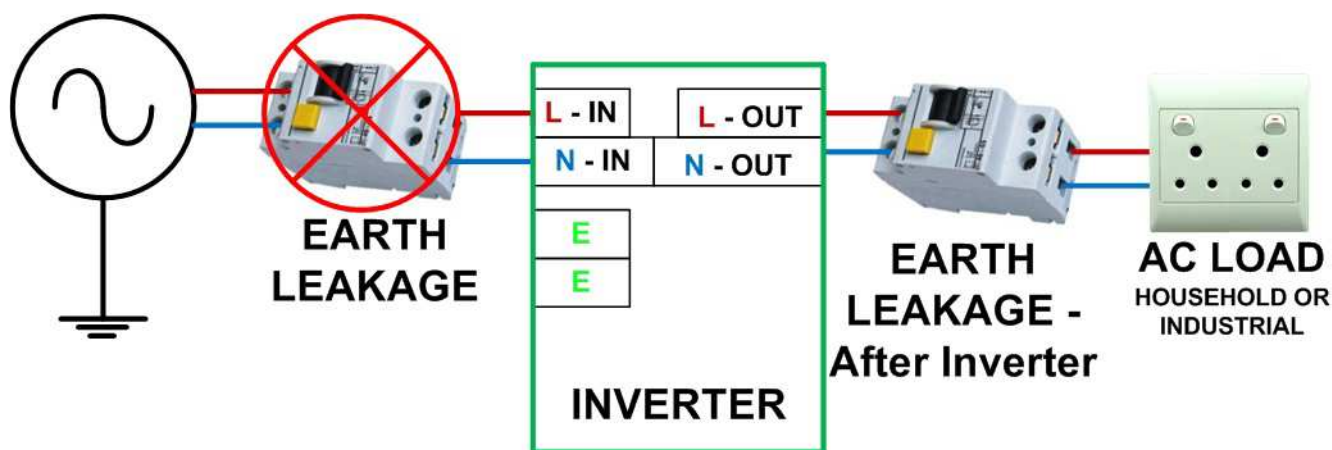

When Mains Power Is connected to the inverter the neutral will be earthed via the mains connection and the system does therefore not have to be earthed.

#### 2.3.6 Inverter Earth Connection Off-Grid.

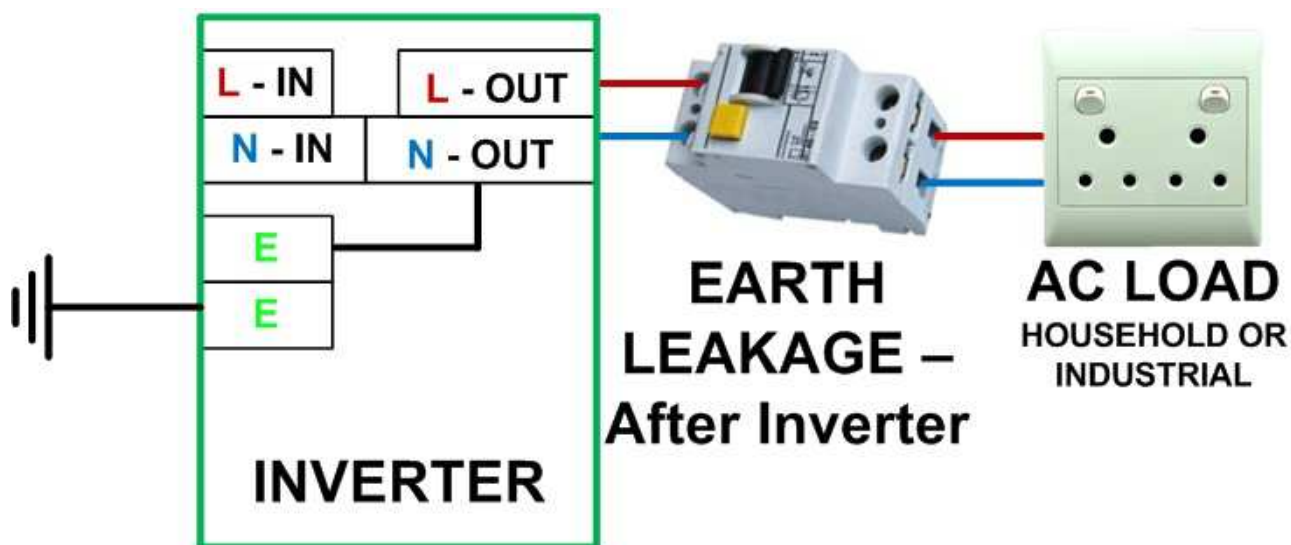

When the inverter is connected as an off-grid or stand alone inverter then the earth connection needs to be bridged out.

## 2.4 MAINTENANCE AND SERVICE

1. Caution – Risk of Electric Shock.
2. Batteries may cause electric shock and have a high short-circuit current. Please take the precautionary measures specified below and any other measures necessary when working with batteries.
  - Remove wristwatches, rings and other metal objects.
  - Use only tools with insulated grips and handles.

## 3. SYSTEM DESCRIPTION

### 3.1 SYSTEM DESCRIPTION. (1Kw; 2Kw; 3Kw and 5Kw Inverters.)

#### 3.1.1 System Front View. (1Kw – 5Kw Inverters.)

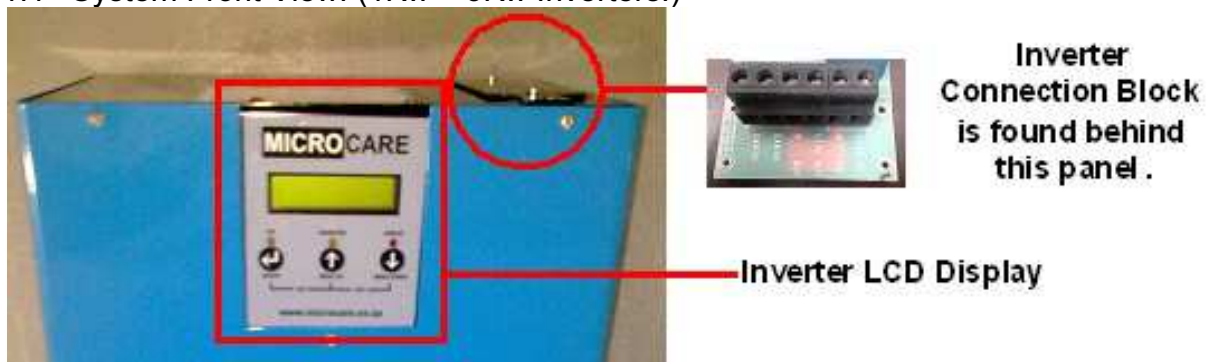

#### 3.1.2 System Back View. (1Kw – 5Kw Inverters.)

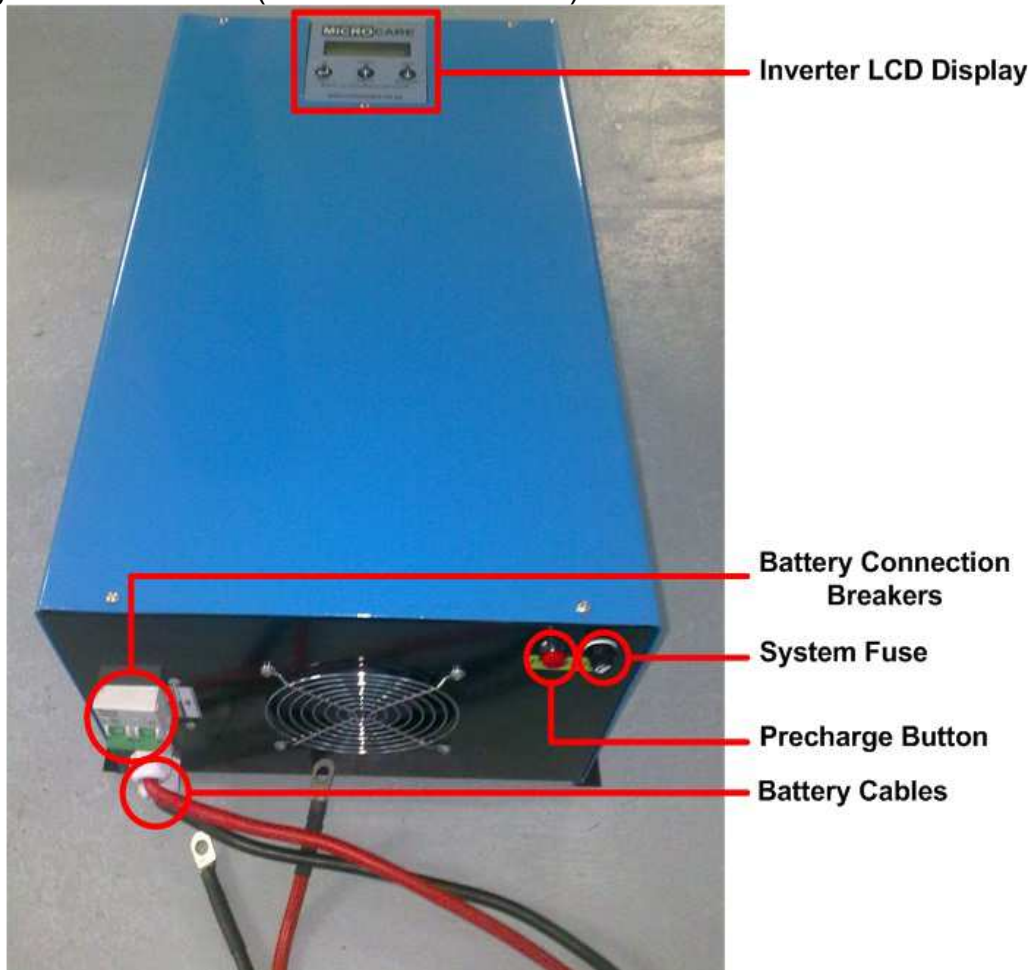

## 3.2 FRONT PANEL DESCRIPTION



- 3.2.1 LCD Display: This indicates the UPS's operational information, including output voltage, battery voltage, output load and inside temperature.
- 3.2.2 UP–Key: Use to move the display up.
- 3.2.3 DOWN–Key: Use to move the display down.
- 3.2.4 ENTER–Key: It is pressed with the UP–Key to turn on the UPS. Push the ENTER button to confirm or store DATA.
- 3.2.5 Push the UP and DOWN keys together to turn off the inverter.
- 3.2.6 Fault LED (Red): To indicate the INVERTER is in a fault condition because of inverter shutdown or over temperature.
- 3.2.7 Warning LED (Yellow): To indicate the INVERTER is in the status of overload or battery LOW.
- 3.2.8 Normal LED (Green): To indicate the INVERTER is operating normally.

## 3.2 MAINTENANCE AND SERVICE

Wall mount unit.



# 4. INVERTER OPERATION

## 4.1 Check Prior to Start Up

- 4.1.1 Ensure the INVERTER is mounted vertically.
- 4.1.2 Check Input and Output cables are secured.
- 4.1.3 Check if Battery voltage meets the INVERTER rating.

## 4.2 Operation Procedure

Please follow the instructions below for the UPS operation.

Push and hold the **RED PRECHARGE BUTTON** until the Display comes on and shows the following:

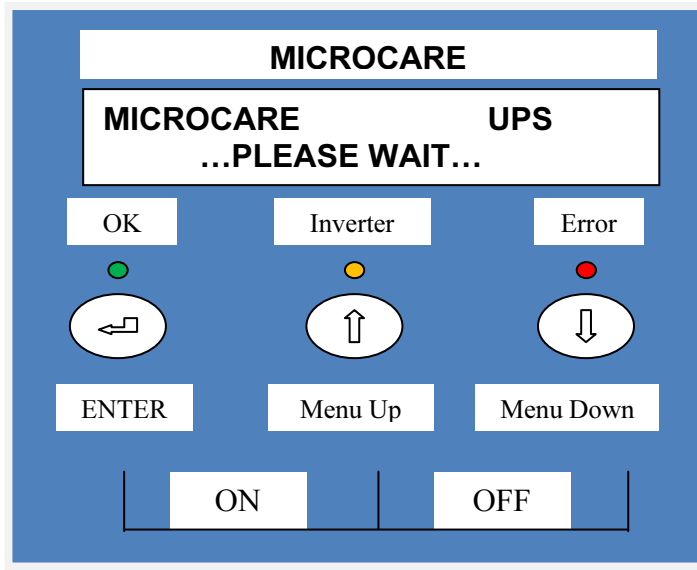

The display then changes to:

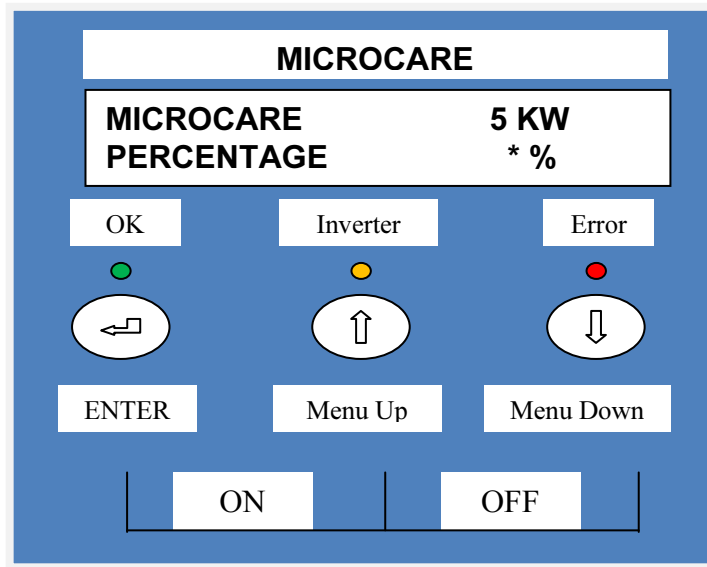

The display then changes to:

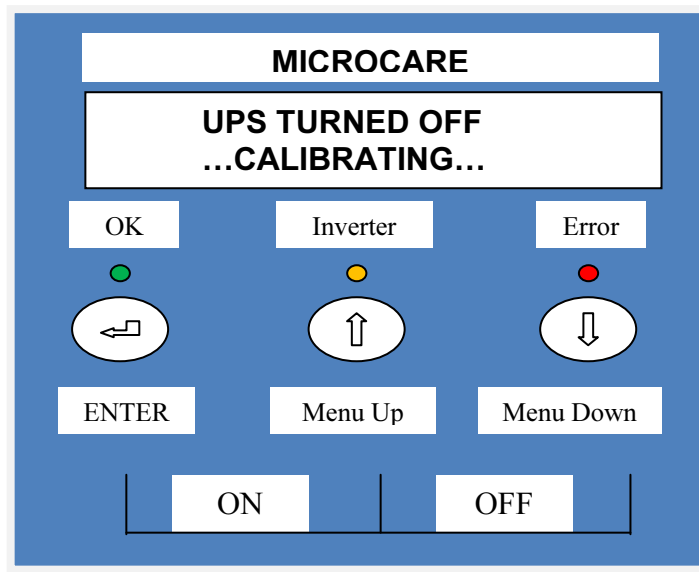

The display then changes to:

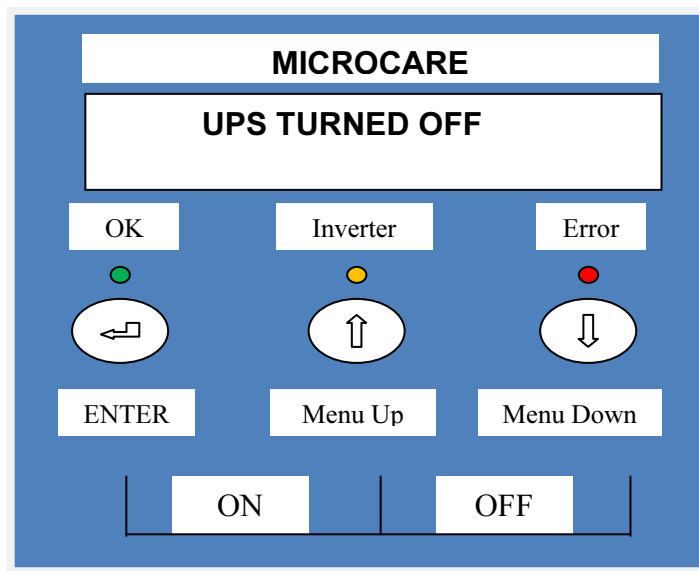

While holding in the **PRECHARGE BUTTON** turn on the MAIN CIRCUIT BREAKER.

By pressing the Enter-key and the UP-key simultaneously for 3 seconds, the UPS will start up and the OK LED will light up to indicate the power is being supplied from the inverter to the load and the MAINS / FAIL LED comes ON. The display will show:

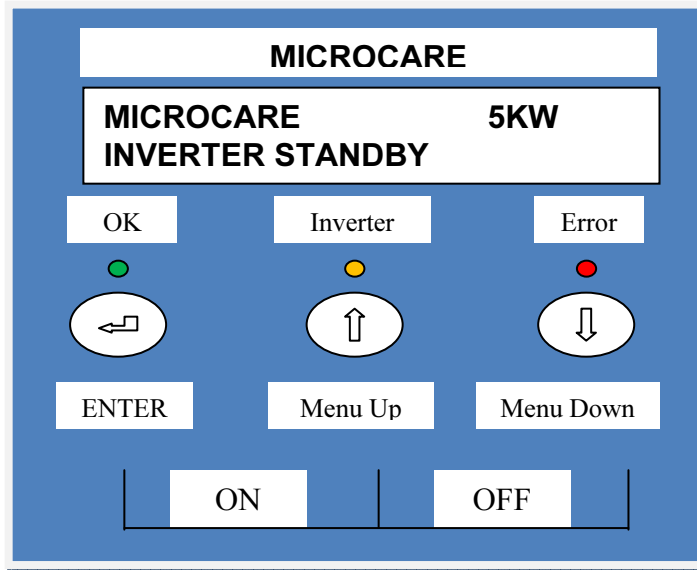

By turning on a load the **OUTPUT %** will change to indicate the amount of **LOAD** as a % of the unit being used in KW.

When the Up-key and the Down-key are pressed simultaneously for 3 seconds, the UPS will be turned **OFF** after two beeps.

#### LCD DISPLAY MENU

With the inverter in the ON position use the Up/Down keys to select menu-displays of the LCD described below.

The screen will show the following:

**INV TURNED ON** Push the **OK** button.

Using the **UP/Down** Buttons the following screens can be seen.

This shows the power rating of the UPS and its % output.

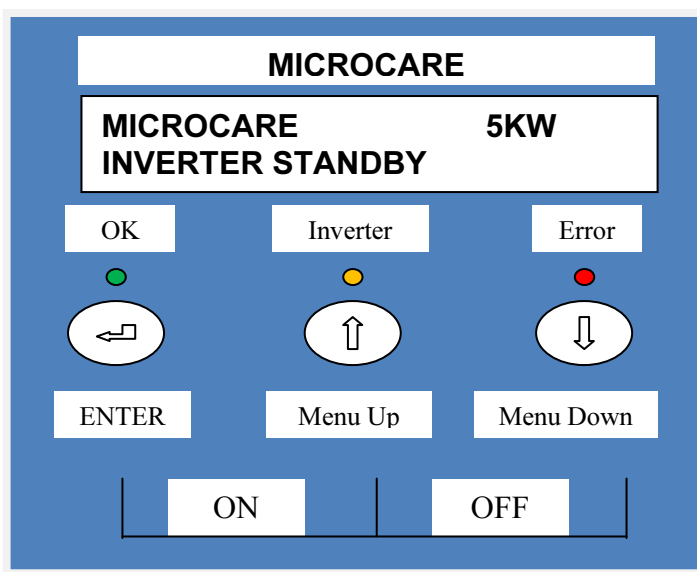

Using the UP arrows the following details can be checked:

This shows the battery voltage and the amps that the UPS is drawing from the battery.

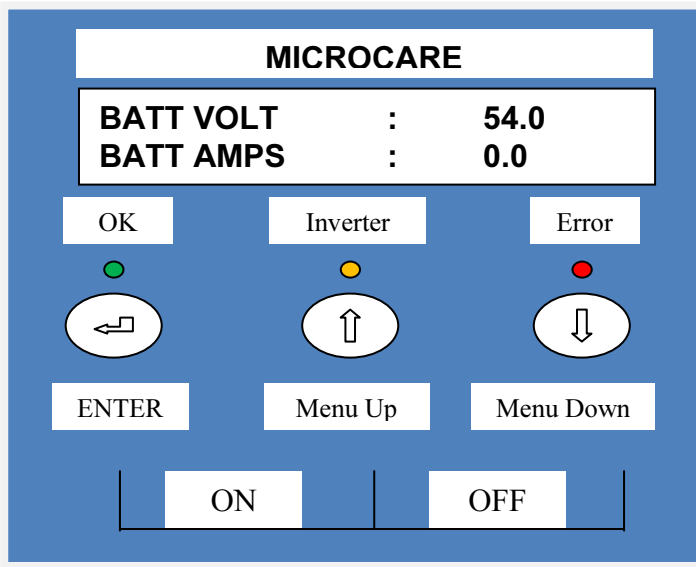

This shows the output voltage and amps that the load is drawing from the Inverter.

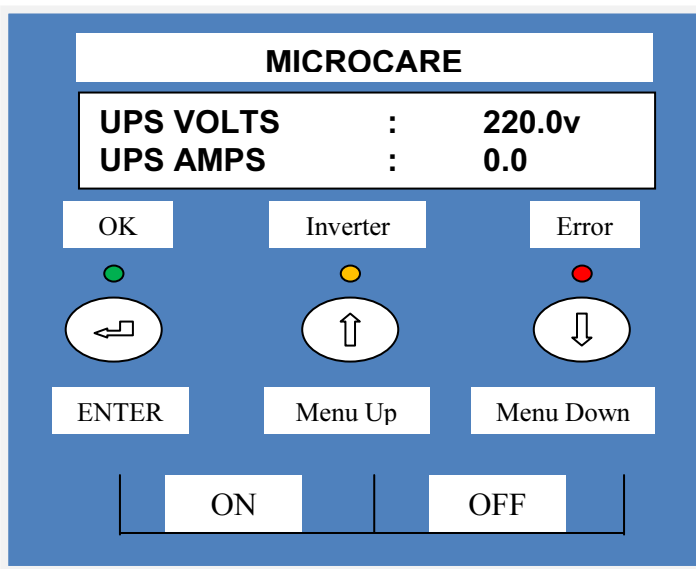

This shows the internal temperature of the UPS.

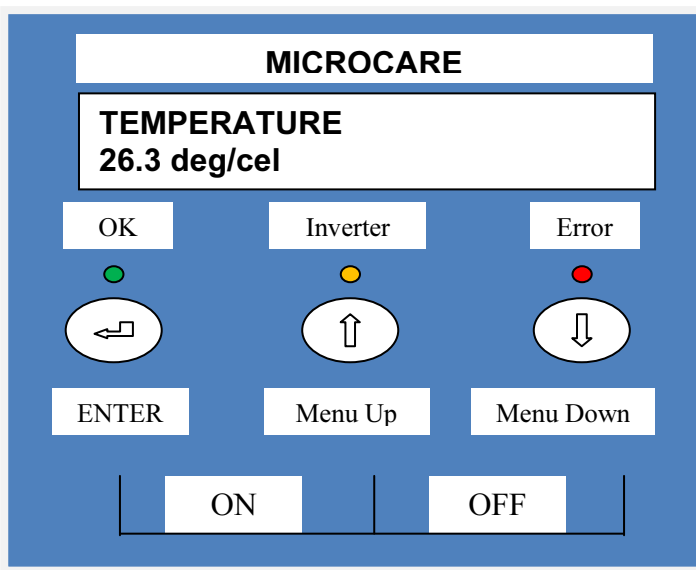

This shows that the control cards in the UPS have a 100% communication level.

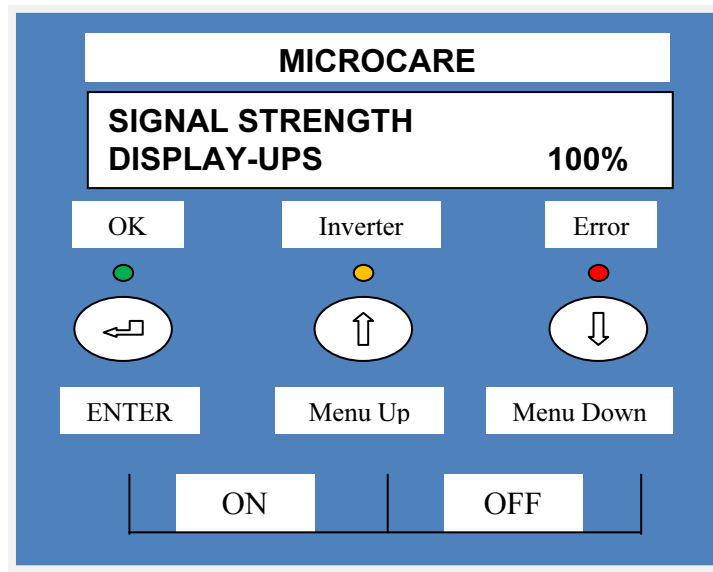

This indicates the serial number of the Inverter.

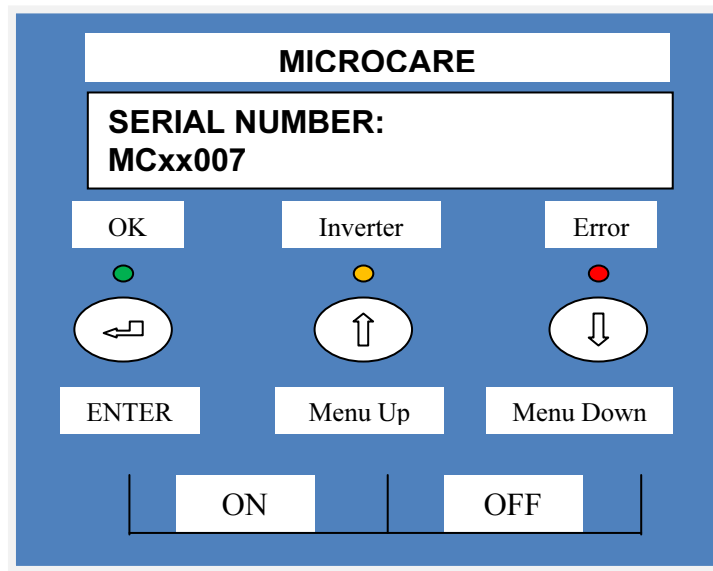

## 5. INVERTER PROGRAMMING

There are two MENUS' which allow the user to change either the SET UP or the BATTERY menus.

Push the UP / DOWN keys to select which menu is to be changed.

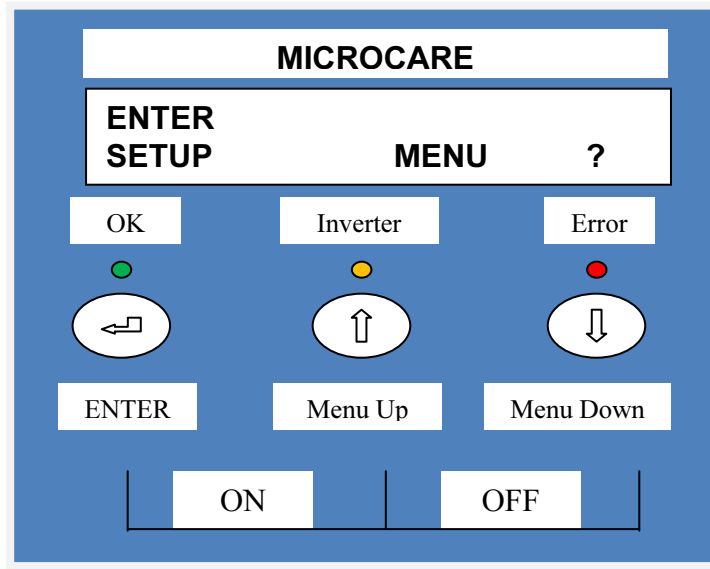

Push ENTER if you want to change the set up menu.

By pushing ENTER you can change whether the inverter runs in **MANUAL** mode; **AUTO** mode or **SOLAR** mode. In the **AUTO** mode the inverter uses the least amount of battery power when there is no load, however **AUTO** mode should only be used in remote areas where power is not required constantly.

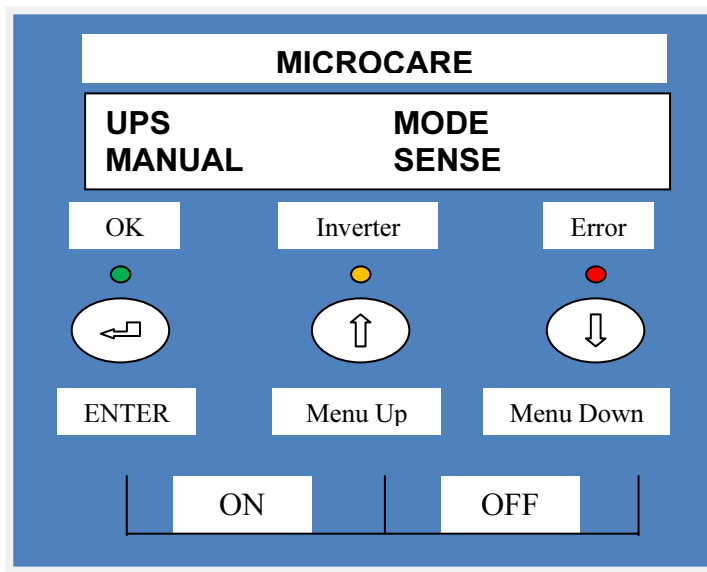

Push the ENTER button. The menu changes to:

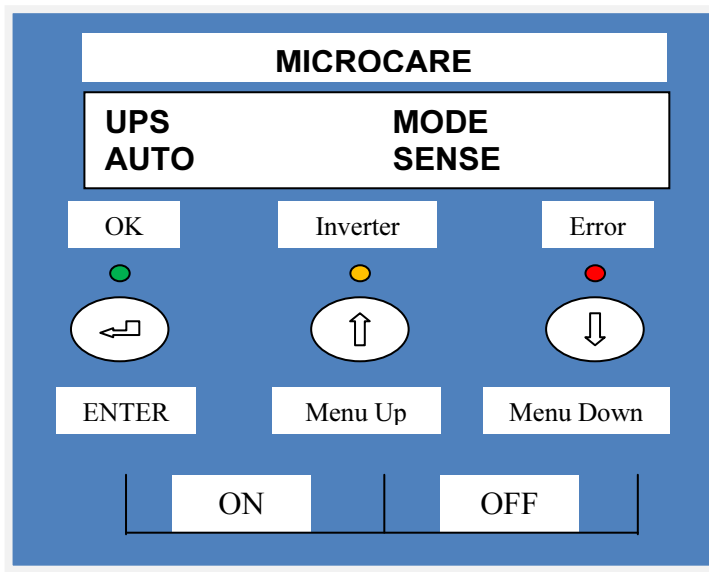

Push the ENTER button. The menu changes to:

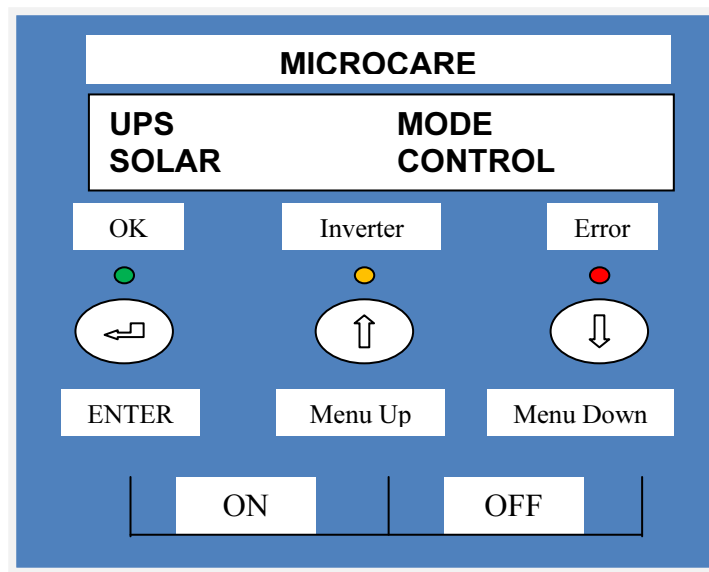

**In order to run correctly in Solar Control Mode, the BATTERY OFF AT setup needs to be changed in the BATTERY SETUP MENU to: (2V – 48V; 1.5V – 36V; 1V – 24V; 0.5V – 12V) Less than the BATTERY RUN TO Value setup in the SETUP MENU.**

When the inverter is running in solar control mode and the Charge level is set to LEVEL 1, the inverter will run the load using mains power and the solar regulator will charge the battery bank. The inverter will switch back over to battery power when the AC RUN TO Value is reached.

Push the UP button in SOLAR mode you can then access the battery run to menu:  
 (This allows the user to set the level the battery will go down to before switching to mains power.)

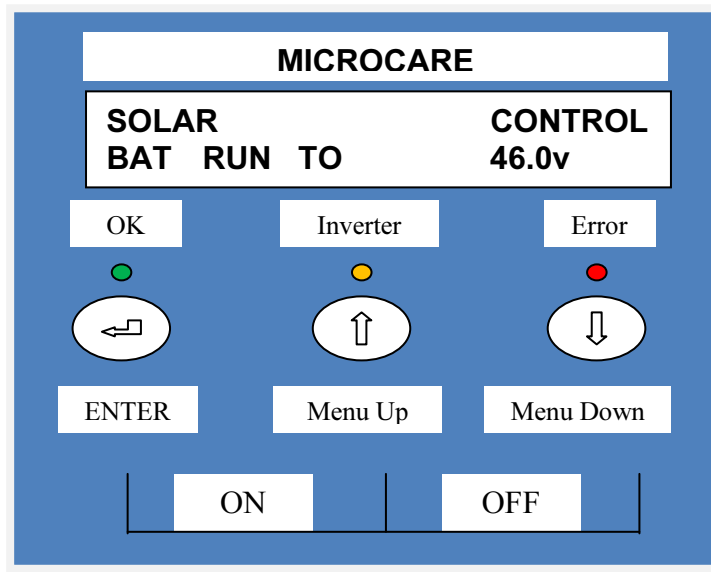

Battery Run To: 48v System – 46v (Default) (Can be changed in 2v Increments)  
 36v System – 34.5v (Default) (Can be changed in 1.5v Increments)  
 24v System – 23v (Default) (Can be changed in 1v Increments)  
 12v System – 11.5v (Default) (Can be changed in 0.5v Increments)

Push the ENTER button. The Menu settings can be changed.

Push the UP button. The menu changes to AC RUN TO menu:  
 (Allows the user to set the level the mains will charge the battery to before the inverter switches back to battery power.)

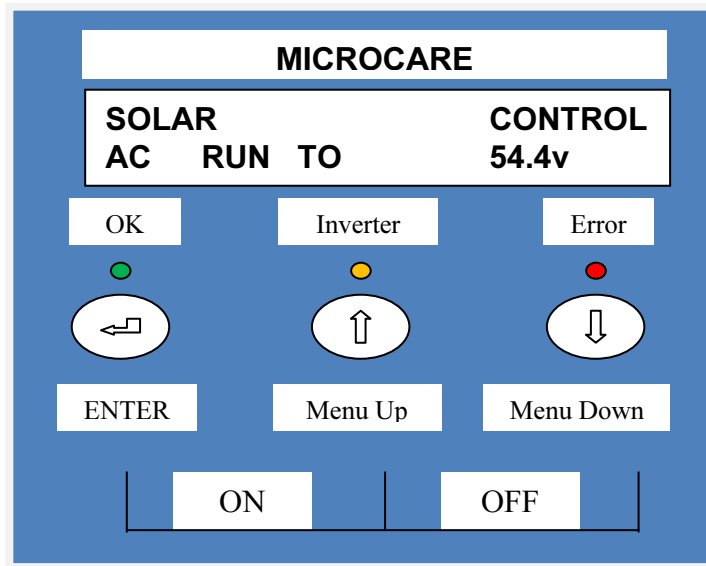

AC Run To: 48v System – 54.4v (Default) (Can be changed in 2v Increments)  
 36v System – 40.5v (Default) (Can be changed in 1.5v Increments)  
 24v System – 24v (Default) (Can be changed in 1v Increments)  
 12v System – 12v (Default) (Can be changed in 0.5v Increments)

Push the ENTER button. The Menu settings can be changed.



Push the UP button. The menu changes to:

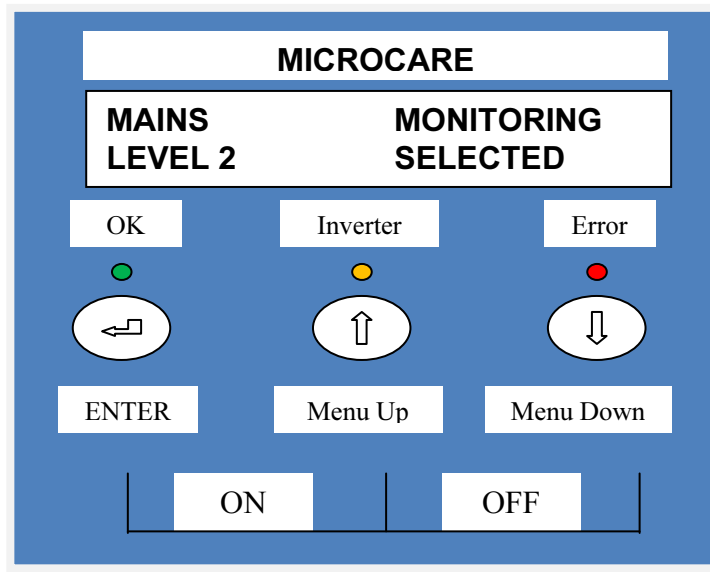

This may be selected between LEVEL 1 which is the most sensitive to LEVEL 3 which is the least sensitive by pushing the ENTER button.

To change the menu, push the UP button.

The menu will then change to:

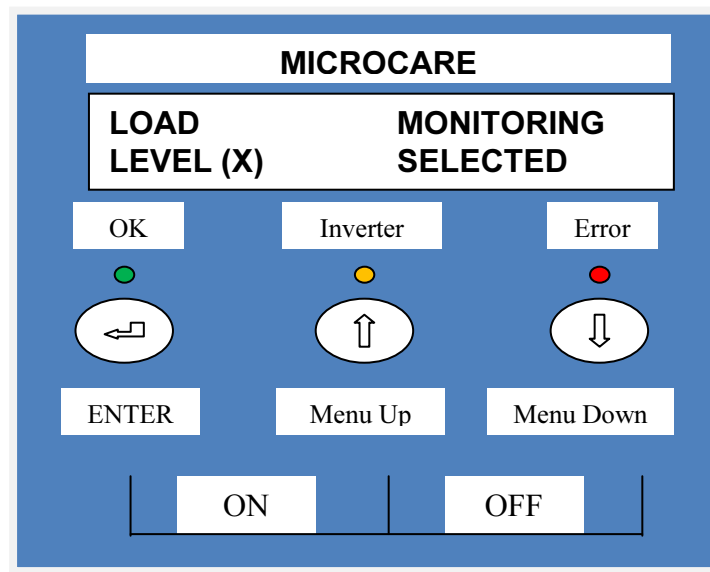

The sensitivity of the **OVERLOAD TRIP** may be changed thru 5 LEVELS. The factory default level is 2. Level 1 is HIGH and 2 is MEDIUM. These are instant trips. Levels 3 and 4 are HIGH and MEDIUM but have a 3 retry operation. If the inverter trips then it will try to restart using a soft start mode. LEVEL 5 is LOW. Push ENTER to select the mode.

Pushing the UP button will give you 3 options to SAVE the changed data. The display will show:

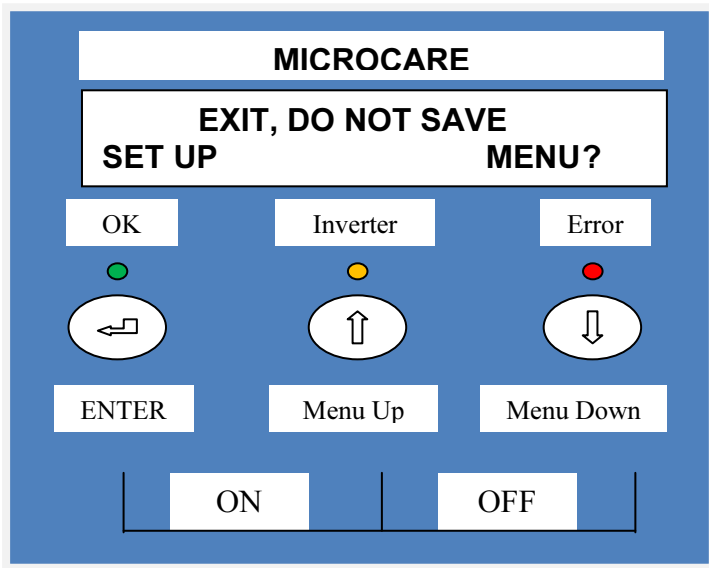
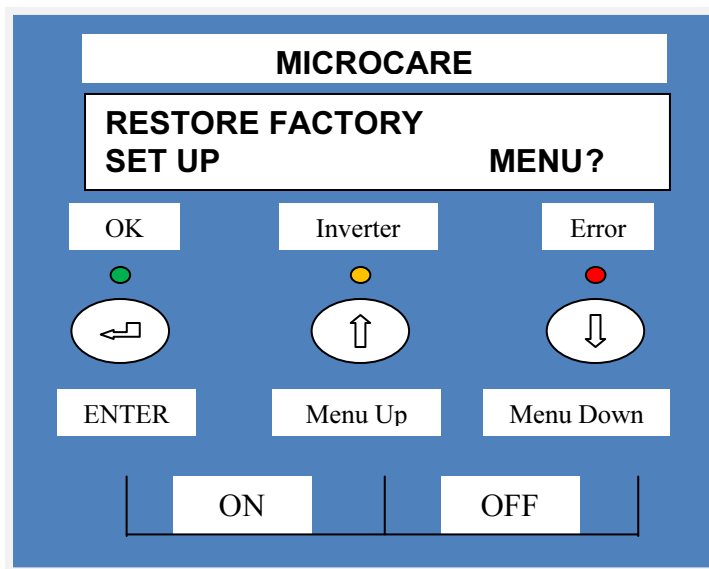
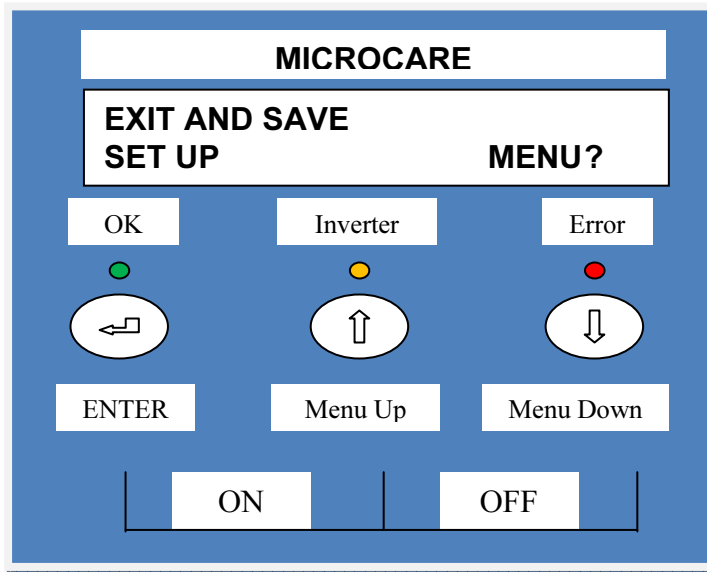

If the changes to the settings need to be saved push ENTER if the enter button is pushed for any of the above then the unit will show:

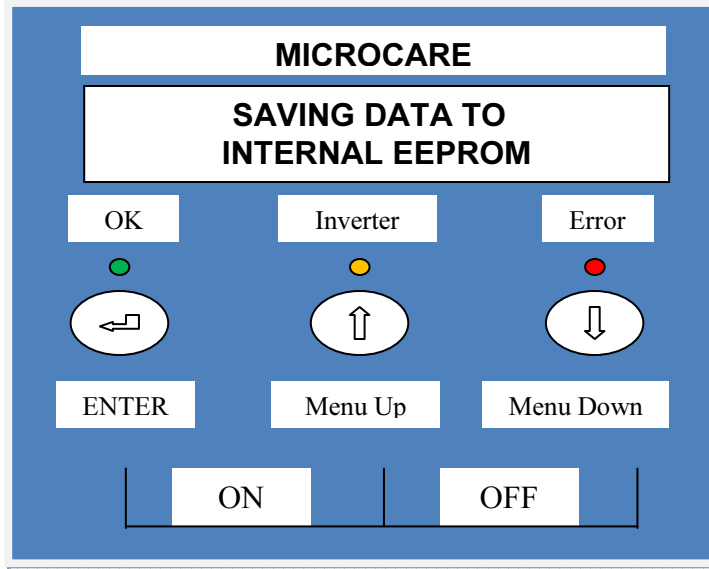

If no entry is made for 1 minute the display will return to the main menu and the back light will turn off.

Use the UP button to select BATTERY menu:

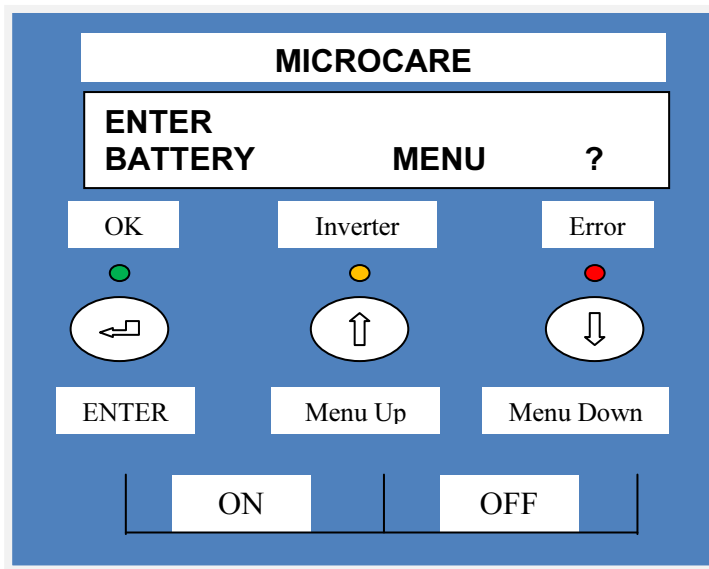

To change the **BATTERY CHARGE** menu push ENTER, the following will show:

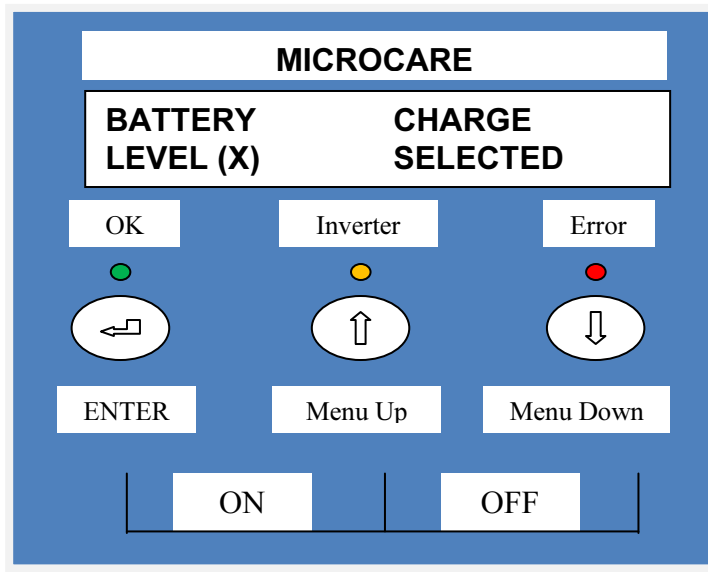

This allows the user to program the charge rate from 0 to 100%. LEVEL 4 is the factory default. Level 1 is 0%, Level 2 is 5%, Level 3 is 25%, Level 4 is 50%, Level 5 is 75%, Level 6 is 100%.

INVERTER	CHARGE AMPS
1Kw12V	40A
1Kw24V	30A
1Kw36V	20A
1Kw48V	10A
2Kw12V	80A
2Kw24V	40A
2Kw36V	30A
2Kw48V	20A
3Kw24V	60A
3Kw36V	40A
3Kw48V	30A
5Kw24V	100A
5Kw36V	75A
5Kw48V	50A

Above is the list of charge amps for all of the inverters.

In regards to the battery charge level – The Level selected will allow the battery charge to the batteries.

LEVEL 3 – 25% – On a 5Kw48V Inverter will allow a charge of 12.5A to the battery.

LEVEL 5 – 75% – On a 5Kw48V Inverter will allow a charge of 37.5A to the battery.

Push the UP button. The menu changes to:

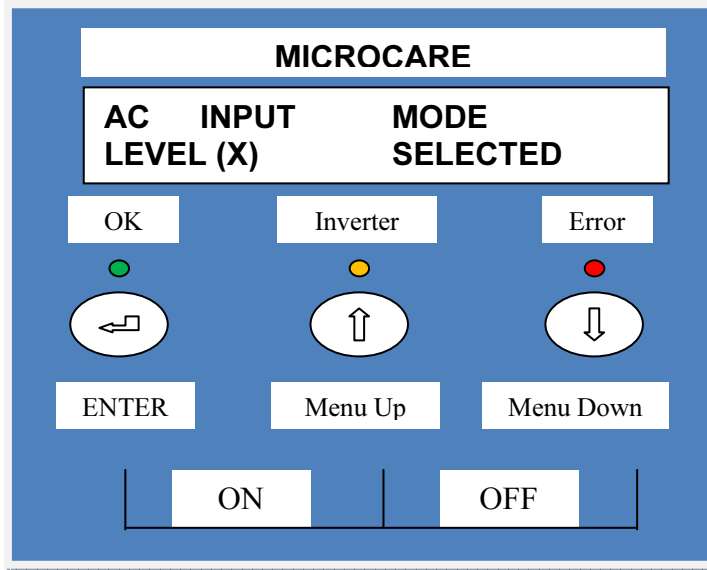

This allows the UPS to extract the maximum amount of power from a generator. The UPS constantly monitors the voltage from the generator and then applies maximum charge. LEVEL 1 is the lightest load to the generator while LEVEL 6 is the maximum. The factory default LEVEL is 1. This only needs to be adjusted if there is a generator connected.

**When a generator is running the generator will supply the AC Load first and the inverter will charge batteries with any excess power created from the generator.**



Push the UP button. The menu changes to:

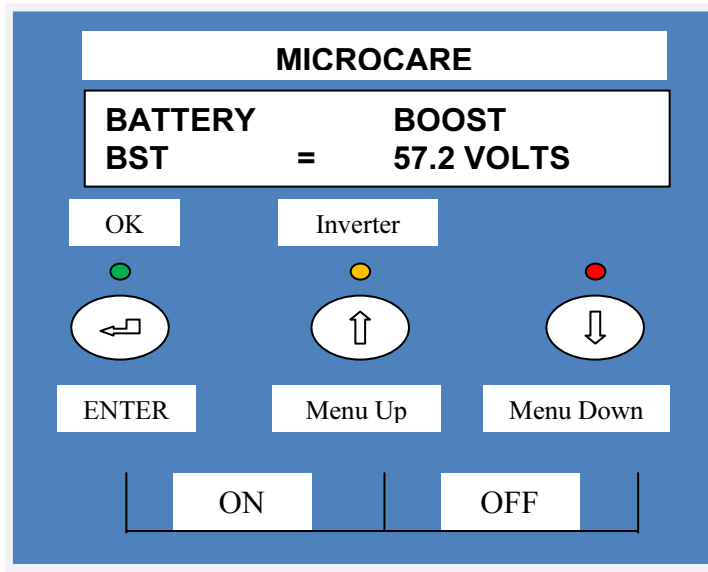

By pushing ENTER this allows the user to adjust the **BATTERY BOOST** voltage.

Push the UP key the next MENU is:

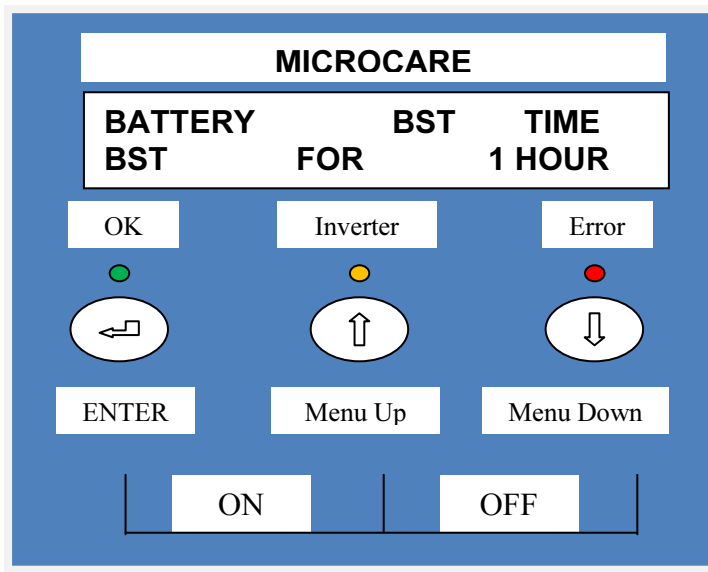

This allows the user to select the **TIME** that the **BOOST VOLTAGE** will be held at before changing to FLOAT. By pushing ENTER you can select 1, 2 or 3 hours.

Push the UP button. The menu changes to:

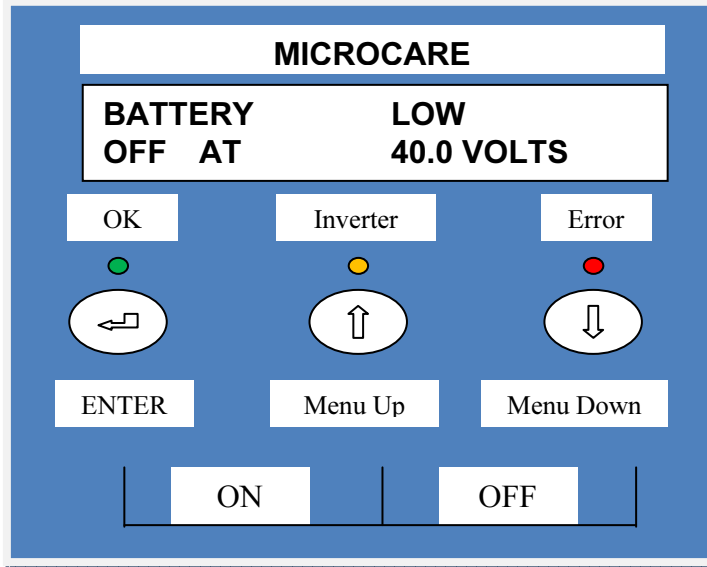

This selects at what **BATTERY LOW VOLTAGE** the UPS will shut down. By pushing ENTER you can select to change the voltage.

Push the UP button.

It is possible to **FORCE** the charger to go into another charge mode on a temporary basis. If the charger is in FLOAT but you require it to go back into BOOST then the next menu will allow this.

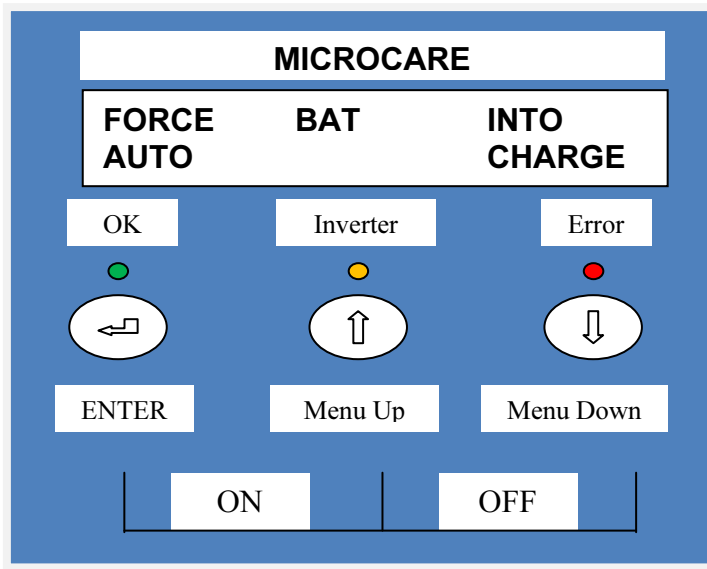

Pushing the ENTER button allows the charge to be changed from **AUTO** to **BOOST** or **FLOAT**.

Push the UP button:

This will give you the options of saving the changes that have been made. Push ENTER at the correct **SAVE** menu.

## 6. SPECIFICATIONS OF INVERTERS

		MODEL 12/1000	MODEL 12/2000
<b>Capacity</b>	<b>Watt</b>	1000	2000
<b>Input</b>	<b>Nominal Voltage</b>	12 Vdc	12 Vdc
	<b>Acceptable Voltage Range</b>	10-15 Vdc	10-15 Vdc
	<b>Maxi Input Amps</b>	100	200
	<b>Standby Power (manual mode)</b>	15 watts	24 watts
	<b>Standby Power ( search mode)</b>	8 watts	8 watts
<b>Output</b>	<b>Voltage</b>	220 Vac	220 Vac
	<b>Amps</b>	5 amps	10 amps
	<b>Voltage Regulation</b>	< 3 % RMS for entire battery voltage range	< 3 % RMS for entire battery voltage range
	<b>Frequency</b>	50Hz	50Hz
	<b>Frequency Regulation</b>	± 0.1Hz	± 0.1Hz
	<b>Power Factor</b>	1	1
	<b>Wave Form</b>	Pure Sine Wave	Pure Sine Wave
	<b>Efficiency</b>	96%	96%
	<b>Overload Protection</b>	Circuit Breaker Programmable Overload levels and Auto Retry	Circuit Breaker Programmable Overload levels and Auto Retry
<b>Charger</b>	<b>Float Voltage</b>	13.8	13.8
	<b>Boost Voltage</b>	13.8.....15.5	13.8.....15.5
	<b>Boost Time</b>	Selectable 1, 2, 3 hours.	Selectable 1, 2, 3 hours.
	<b>Maximum Current</b>	40 amps	80 amps
	<b>Generation Mode</b>	Depending on the generator power available.	Depending on the generator power available.



		<b>MODEL 24/1000</b>	<b>MODEL 24/2000</b>	<b>MODEL 24/3000</b>	<b>MODEL 24/5000</b>
<b>Capacity</b>	<b>Watt</b>	1000	2000	3000	5000
<b>Input</b>	<b>Nominal Voltage</b>	24 Vdc	24 Vdc	24 Vdc	24 Vdc
	<b>Acceptable Voltage Range</b>	20-30 Vdc	20-30 Vdc	20-30 Vdc	20-30 Vdc
	<b>Maxi Input Amps</b>	55	75	150	250
	<b>Standby Power (manual mode)</b>	20 watts	40 watts	60 watts	100 watts
	<b>Standby Power ( search mode)</b>	10 watts	15 watts	15 watts	20 watts
<b>Output</b>	<b>Voltage</b>	220 Vac	220 Vac	220 Vac	220 Vac
	<b>Amps</b>	5 amps	10 amps	14 amps	22 amps
	<b>Voltage Regulation</b>	< 3 % RMS for entire battery voltage range	< 3 % RMS for entire battery voltage range	< 3 % RMS for entire battery voltage range	< 3 % RMS for entire battery voltage range
	<b>Frequency</b>	50Hz	50Hz	50Hz	50Hz
	<b>Frequency Regulation</b>	± 0.1Hz	± 0.1Hz	± 0.1Hz	± 0.1Hz
	<b>Power Factor</b>	1	1	1	1
	<b>Wave Form</b>	Pure Sine Wave	Pure Sine Wave	Pure Sine Wave	Pure Sine Wave
	<b>Efficiency</b>	> 90 %	> 90 %	> 90 %	> 90 %
		Circuit Breaker	Circuit Breaker	Circuit Breaker	Circuit Breaker
	<b>Overload Protection</b>	110 % ~ 150 % for 30 Sec, > 150 % for 200ms	Programmable Overload levels and Auto Retry	Programmable Overload levels and Auto Retry	110 % ~ 150 % for 30 Sec, > 150 % for 200ms
<b>Charger</b>	<b>Float Voltage</b>	27.6	27.6	27.6	27.6
	<b>Boost Voltage</b>	28.6.....31	27.6.....31	28.6.....31.0	28.6.....31.0
	<b>Boost Time</b>	Selectable 1, 2, 3 hours	Selectable 1, 2, 3 hours.	Selectable 1, 2, 3 hours.	Selectable 1, 2, 3 hours.
	<b>Maximum Current</b>	25 amps	40 amps	60 amps	100 amps
	<b>Generation Mode</b>	Depending on the generator power available.	Depending on the generator power available	Depending on the generator power available.	Depending on the generator power available.

		<b>MODEL 36/5000</b>
<b>Capacity</b>	<b>Watt</b>	5000
<b>Input</b>	<b>Nominal Voltage</b>	36 Vdc
	<b>Acceptable Voltage Range</b>	30-45 Vdc
	<b>Maxi Input Amps</b>	150
	<b>Standby Power (manual mode)</b>	60 watts
	<b>Standby Power ( search mode)</b>	20 watts
<b>Output</b>	<b>Voltage</b>	220 Vac
	<b>Amps</b>	22 amps
	<b>Voltage Regulation</b>	< 3 % RMS for entire battery voltage range
	<b>Frequency</b>	50Hz
	<b>Frequency Regulation</b>	± 0.1Hz
	<b>Power Factor</b>	1
	<b>Wave Form</b>	Pure Sine Wave
	<b>Efficiency</b>	90%
		Circuit Breaker
	<b>Overload Protection</b>	110 % ~ 150 % for 30 Sec, > 150 % for 200ms
<b>Charger</b>	<b>Float Voltage</b>	41.4
	<b>Boost Voltage</b>	42.9.....46.5
	<b>Boost Time</b>	Selectable 1, 2, 3 hours.
	<b>Maximum Current</b>	70 amps
	<b>Generation Mode</b>	Depending on the generator power available.

		<b>MODEL 48/1000</b>	<b>MODEL 48/2000</b>	<b>MODEL 48/3000</b>	<b>MODEL 48/5000</b>
<b>Capacity</b>	<b>Watt</b>	1000	2000	5000	3000
<b>Input</b>	<b>Nominal Voltage</b>	48 Vdc	48 Vdc	48 Vdc	48 Vdc
	<b>Acceptable Voltage Range</b>	40-60 Vdc	40-60 Vdc	40-60 Vdc	40-60 Vdc
	<b>Maxi Input Amps</b>	25	75	125	75
	<b>Standby Power (manual mode)</b>	30 watts	30 watts	60 watts	48 watts
	<b>Standby Power ( search mode)</b>	10 watts	10 watts	20 watts	15 watts
<b>Output</b>	<b>Voltage</b>	220 Vac	220 Vac	220 Vac	220 Vac
	<b>Amps</b>	5 amps	10 amps	22 amps	14 amps
	<b>Voltage Regulation</b>	< 3 % RMS for entire battery voltage range	< 3 % RMS for entire battery voltage range	< 3 % RMS for entire battery voltage range	< 3 % RMS for entire battery voltage range
	<b>Frequency</b>	50Hz	50Hz	50Hz	50Hz
	<b>Frequency Regulation</b>	± 0.1Hz	± 0.1Hz	± 0.1Hz	± 0.1Hz
	<b>Power Factor</b>	1	1	1	1
	<b>Wave Form</b>	Pure Sine Wave	Pure Sine Wave	Pure Sine Wave	Pure Sine Wave
	<b>Efficiency</b>	96%	96%	90 % @ 90% Load	96%
	<b>Overload Protection</b>	Circuit Breaker	Circuit Breaker	Circuit Breaker	Circuit Breaker
		Programmable Overload levels and Auto Retry	Programmable Overload levels and Auto Retry	Programmable Overload levels and Auto Retry	Programmable Overload levels and Auto Retry
<b>Charger</b>	<b>Float Voltage</b>	55.2	55.2	55.2	55.2
	<b>Boost Voltage</b>	57.2V-62.0V	57.2V-62.0V	57.2V-62.0V	57.2V-62.0V
	<b>Boost Time</b>	Selectable 1, 2, 3 hours.	Selectable 1, 2, 3 hours.	Selectable 1, 2, 3 hours.	Selectable 1, 2, 3 hours.
	<b>Maximum Current</b>	10 amps	20 amps	50 amps	30 amps
	<b>Generation Mode</b>	Depending on the generator power available.	Depending on the generator power available.	Depending on the generator power available.	Depending on the generator power available.

## MICROCARE LIMITED WARRANTY

Microcare warrants its full range of products against defects in workmanship and materials, fair wear and tear accepted, for a period of three (3) years from the date of delivery/collection for all equipment and are based on a bring-in-basis. Where the installation of the product makes it impractical to bring-in to our workshops, Microcare reserves the right to charge for travel time and kilometres travelled to and from the site where the product is installed.

During this warranty period, Microcare will, at its own discretion, repair or replace the defective product free of charge. This warranty will be considered void if the unit has suffered any physical damage or alteration, either internally or externally, and does not cover damages arising from improper use such as, but not exclusive to:

- Reverse of battery polarity.
- Inadequate or incorrect connection of the product and/or of its accessories.
- Mechanical shock or deformation.
- Contact with liquid or oxidation by condensation.
- Use in an inappropriate environment (dust, corrosive vapour, humidity, high temperature, biological infestation).
- Breakage or damage due to lightning, surges, spikes or other electrical events.
- Connection terminals and screws destroyed or other damage such as overheating due to insufficient tightening of terminals.
- When considering any electronic breakage except due to lightning, reverse polarity, over-voltage, etc. the state of the internal control circuitry determines the warranty.

This warranty will not apply where the product has been misused, neglected, improperly installed, or repaired by anyone else than Microcare or one of its authorised Qualified Service Partners. In order to qualify for the warranty, the product must not be disassembled or modified. Repair or replacement are our sole remedies and Microcare shall not be liable for damages, whether direct, incidental, special, or consequential, even caused by negligence or fault. Microcare owns all parts removed from repaired products. Microcare uses new or re-conditioned parts made by various manufacturers in performing warranty repairs and building replacement products. If Microcare repairs or replaces a part of a product, its warranty term is not extended. Removal of serial nos. may void the warranty.

All remedies and the measure for damages are limited to the above. Microcare shall in no event be liable for consequential, incidental, contingent or special damages, even if having been advised of the probability of such damages. Any and all other warranties expressed or implied arising by law, course of dealing, course of performance, usage of trade or otherwise, including but not limited to implied warranties of merchantability and fitness for a particular purpose, are limited in duration to a period of three (3) years from the date of purchase.

**Life Support Policy:**

As a general policy, Microcare does not recommend the use of any of its products in life support applications where failure or malfunction of the Microcare product can be reasonably expected to cause failure of the life support device or to significantly affect its safety or effectiveness. Microcare does not recommend the use of any of its products indirect patient care. Microcare will not knowingly sell its products for use in such applications unless it receives in writing assurances satisfactory to Microcare that the risks of injury or damage have been minimised, the customer assumes all such risks, and the Liability of Microcare is adequately protected under the circumstances.

**Caution:**

Our products are sensitive. While all care is taken by us to dispatch goods with adequate packaging, Microcare is not responsible for any damaged caused to products after they have left our premises. Semi-sealed batteries have to be transported upright and must not be put on their side. Please ensure that your transport company or delivery team is aware of the sensitivity of the products they are collecting.

**Goods return policy:**

The following terms apply to returns of items purchased from Microcare, and we require the following information:

1. Details of the item(s) you would like to return.
2. Our invoice number.
3. The reason for the return.
4. Microcare must be notified within 7 days of your intention to return the goods which were purchased.
5. All items returned will be inspected prior to refund. If our technicians are not immediately available, the goods will have to be left with us until such time as a technician is available to check the items.
6. Proof of purchase is required for all returns.
7. The price paid by the customers is the price on which the refund is based.
8. Items purchased can be returned for a refund, replacement or exchange, provided proof of purchase is provided and subject to all other conditions as set down here.
9. All returns may be subject to an administration and handling fee of 10% of purchase price plus VAT.
10. Returns are based on a bring-in basis.
11. Returns will be refused in the following circumstances:
  - a. Where an item has been tampered with, altered or damaged in any way, or
  - b. Where a return is deemed unreasonable, this will be referred to management.

**Severability:**

If a part of the terms and conditions set out above is held invalid, void, or unenforceable due to any particular national or international legislation, it shall not affect other parts of the terms and conditions remaining.

---